

Kubíček Factory s.r.o.  
Jarní 1003/2a, 614 00 Brno  
Czech Republic  
+420 545 422 620  
info@kubicekfactory.com  
www.kubicekfactory.com

# *Hot Air Balloon* **Flight Manual**

**Type:** .....

**Model:** .....

**Serial No.** .....

**Registration:** .....

This manual is initially approved by EASA under major change approval number 10061892, dated 15 May 2017. Subsequent revisions are approved either by EASA or their technical content is approved under the authority of the DOA, ref.: EASA.21J.277. as detailed on page III - IV.

**This balloon is to be operated in compliance with information and limitations contained herein.  
The Flight Manual has to be placed in the basket during flight.**

# KUBICEK

## Reduced Maximum Take-off Weight

RMTOW	Date of change	Approved by Kubíček Factory s.r.o. (date, signature)

The definition of the RMTOW is provided in section 1.4.

## Balloon Weight Record

Component	Serial number	Weight
Envelope		
Burner		
Basket		
Total Empty Weight		

No.	Cylinder type	Cylinder serial number	Empty weight	Full weight
1				
2				
3				
4				
5				
6				
7				
8				

## Envelope Parts Specification:

Component	Type
Rotation vent	
Deflation system/ Fast deflation system	
Flying wires – compatible with the burner frame	

## REPLACEMENT OF COMPONENTS

The use of baskets, burners and fuel cylinders other than above mentioned is allowed under these conditions:

- all components and their combination are allowed by this Manual or by its supplement
- all components are considered airworthy by the appropriate national aviation authority
- the empty weights of all components used are known (i.e. available from labels or by weighing)
- the length of the envelope flying wires corresponds to the burner frame used

**WARNING** Non-compliance to the above rules renders the balloon non-airworthy.

When in doubt, contact KF for advice.

## O - FORMAL INFORMATION

### O.1 Record of Revisions

Any revision of this Manual, except actual weighing data, must be recorded in the following table.

Revision Number	Affected Section	Affected Pages	Date of Issue	Approval	Date of Approval
1	0 8	III, V, VI 6	02 June 2017	DOA EASA.21J.277	02 June 2017
2	0 1 2 3 4 6 7 8	III, IV, V, VI, VII 2, 3 2, 11 4, 6, 7 7, 8, 9, 10, 13, 14, 16, 17, 18, 19, 20, 23 5, 6, 10, 12, 13, 14 1, 2 6, 7	10 January 2018	DOA approved	10 January 2018
3	2 3 7 8	1,6,7,8,9,12 1 1,2 3,4	22 February 2019	10068907	22 February 2019
4	0 8	III, IV, V, VII 7	25 July 2019	DOA EASA.21J.277	25 July 2019
5	0 1 4	III,IV 3,4 5,6,7,8,9,10	15 August 2019	10070714	15 August 2019
6	0 2 5 8	III,IV,V 1,5,9,10,11 4,5 2	07 October 2019	10071148	07 October 2019
7	0 2 3 4 6 8	III,IV,V,VI,VII 3,10 2,6,7,8 10,16,17 10,11,12,13 5	11 October 2019	10071180	11 October 2019
8	0 2 4 5 6 8	III,IV,V 1,5,9,10,11 10 4,5 12 2,4,7	13 December 2019	10072033	13 December 2019
9	0 8	III,V 6	30 July 2020	10073909	30 July 2020
10	0 2 8	III,IV,V 8,9,10,11 3,4	20 August 2020	10074076	20 August 2020
11	0 2 5 8	III,IV,V 5,8,11,12 4,5 1,6	9 December 2020	10075117	9 December 2020
12	0 2 5 8	II,III,IV,V 5,8,10,11 4,5 1,3	11 May 2021	Approval- No-21J.277- MCH-21-001	11 May 2021

Revision Number	Affected Section	Affected Pages	Date of Issue	Approval	Date of Approval
13	0 1 6	IV,V 1,2 4,5	17 March 2022	DOA EASA.21J.277	17 March 2022
14	0 2 3 4 5 6 8 9	IV,V 1,5,9,11,12 5,6 4,19 4,5 1 1,2 1,3	20 July 2022	Approval- No-21J.277- MCH-22—006	20 July 2022
15	0 2 5 8	IV,V 5,8,11 4,5 1	27 Feb 2023	Approval- No-21J.277- MCH-23—011	27 Feb 2023
16	0 3 4 5 6 9	IV,V, VI, VII 3,4,8 13,14,19,20 2 2,3,8,9,13 8,9,10	30 August 2023	10082693	30 August 2023
17	0 1 3 4 5 6 8	IV, V, VI, VII 1 9 4,9, 13, 16 3 5, 9 6, 7	20 May 2024	DOA EASA.21J.277	20 May 2024
18	0 1 2 4 6 7 8 9	IV, V, VI, VIII 1-4 3,6,8,9,12-15 5-12,14, 16-19,22,25 3,10,15 1,2 3 11-15	draft 9 Oct 2024	DOA EASA.21J.277 10085499	1 October 2024 9 Oct 2024
19	0 8	IV, VI 5	18 Dec 2024	DOA EASA.21J.277	18 Dec 2024
20	0 8	IV,V, VI 3,4,5	5 March 2025	DOA EASA.21J.277	5 March 2025

**This Manual is published on Kubíček Factory website: [www.kubicekballoons.com](http://www.kubicekballoons.com).**

**The Maintenance Manual is published on Kubíček Factory website: [www.kubicekballoons.com](http://www.kubicekballoons.com).**

The new or amended text in the revised page is indicated by a black vertical line in the outer margin, and the revision number and the date is shown on the bottom of the page.

<b>CAUTION</b>	<i>Mandatory revisions are introduced by a Service Bulletin published on the Kubíček Factory website: <a href="http://www.kubicekballoons.com">www.kubicekballoons.com</a>.</i>
----------------	---

## 0.2 List of Effective Pages

Page	Revision No.	Date of Issue	Page	Revision No.	Date of Issue
I	rev 0	15 May 2017	4-3	rev 0	15 May 2017
II	rev 12	11 May 2021	4-4	rev 17	20 May 2024
III	rev 13	17 Mar 2022	4-5	rev 18	9 Oct 2024
IV	rev 20	5 March 2025	4-6	rev 18	9 Oct 2024
V	rev 20	5 March 2025	4-7	rev 18	9 Oct 2024
VI	rev 20	5 March 2025	4-8	rev 18	9 Oct 2024
VII	rev 17	20 May 2024	4-9	rev 18	9 Oct 2024
VIII	rev 18	9 Oct 2024	4-10	rev 18	9 Oct 2024
1-1	rev 18	9 Oct 2024	4-11	rev 18	9 Oct 2024
1-2	rev 18	9 Oct 2024	4-12	rev 18	9 Oct 2024
1-3	rev 18	9 Oct 2024	4-13	rev 0	15 May 2017
1-4	rev 18	9 Oct 2024	4-14	rev 18	9 Oct 2024
1-5	rev 0	15 May 2017	4-15	rev 16	30 Aug 2023
1-6	rev 0	15 May 2017	4-16	rev 18	9 Oct 2024
2-1	rev.14	20 Jul 2022	4-17	rev 18	9 Oct 2024
2-2	rev 2	10 Jan 2018	4-18	rev 18	9 Oct 2024
2-3	rev 18	9 Oct 2024	4-19	rev 18	9 Oct 2024
2-4	rev 0	15 May 2017	4-20	rev 16	30 Aug 2023
2-5	rev 15	27 Feb 2023	4-21	rev 2	10 Jan 2018
2-6	rev 18	9 Oct 2024	4-22	rev 18	9 Oct 2024
2-7	rev 3	22 Feb 2019	4-23	rev0	15 May 2017
2-8	rev 18	9 Oct 2024	4-24	rev 2	10 Jan 2018
2-9	rev 18	9 Oct 2024	4-25	rev 18	9 Oct 2024
2-10	rev 12	11 May 2021	5-1	rev 0	15 May 2017
2-11	rev 15	27 Feb 2023	5-2	rev 16	30 Aug 2023
2-12	rev 18	9 Oct 2024	5-3	rev 17	20 May 2024
2-13	rev 18	9 Oct 2024	5-4	rev 15	27 Feb 2023
2-14	rev 18	9 Oct 2024	5-5	rev 15	27 Feb 2023
2-15	rev 18	9 Oct 2024	5-6	rev 0	15 May 2017
3-1	rev 3	22 Feb 2019	6-1	rev 14	20 Jul 2022
3-2	rev 7	11 Oct 2019	6-2	rev 16	30 Aug 2023
3-3	rev 16	30 Aug 2023	6-3	rev 18	9 Oct 2024
3-4	rev 16	30 Aug 2023	6-4	rev 13	17 Mar 2022
3-5	rev 14	20 Jul 2022	6-5	rev 17	20 May 2024
3-6	rev 14	20 Jul 2022	6-6	rev 2	10 Jan 2018
3-7	rev 7	11 Oct 2019	6-7	rev 0	15 May 2017
3-8	rev 16	30 Aug 2023	6-8	rev 16	30 Aug 2023
3-9	rev 17	20 May 2024	6-9	rev 17	20 May 2024
3-10	rev 0	15 May 2017	6-10	rev 18	9 Oct 2024
4-1	rev 0	15 May 2017	6-11	rev 7	11 Oct 2019
4-2	rev 0	15 May 2017	6-12	rev 8	13 Dec 2019

# KUBICEK

Page	Revision No.	Date of Issue
6-13	rev 16	30 Aug 2023
6-14	rev 2	10 Jan 2018
6-15	rev 18	9 Oct 2024
6-16	rev 0	15 May 2017
6-17	rev 0	15 May 2017
6-18	rev 0	15 May 2017
7-1	rev 18	9 Oct 2024
7-2	rev 18	9 Oct 2024
8-1	rev 15	27 Feb 2023
8-2	rev 14	20 Jul 2022
8-3	rev 20	5 March 2025
8-4	rev 20	5 March 2025
8-5	rev 20	5 March 2025
8-6	rev 17	20 May 2024
8-7	rev 17	20 May 2024
8-8	rev 0	15 May 2017
9-1	rev 14	20 Jul 2022
9-2	rev 0	15 May 2017
9-3	rev 14	20 Jul 2022
9-4	rev 0	15 May 2017
9-5	rev 0	15 May 2017
9-6	rev 0	15 May 2017
9-7	rev 0	15 May 2017
9-8	rev 16	30 Aug 2023
9-10	rev 16	30 Aug 2023
9-11	rev 18	9 Oct 2024
9-12	rev 18	9 Oct 2024
9-13	rev 18	9 Oct 2024
9-14	rev 18	9 Oct 2024
9-15	rev 18	9 Oct 2024

Page	Revision No.	Date of Issue

## 0.3 Contents

### 0 - FORMAL INFORMATION

0.1 Record of Revisions.....	III
0.2 List of Effective Pages.....	V
0.3 Contents .....	VII

### SECTION 1 - GENERAL

1.1 Introduction .....	1-1
1.2 Applicability.....	1-1
1.3 Certification Basis.....	1-1
1.4 Definitions and Abbreviations.....	1-1
1.5 Descriptive Data.....	1-3
1.6 Use of Older Types of Equipment .....	1-5
1.7 Night Flying.....	1-5
1.8 General Operational Warnings.....	1-5

### SECTION 2 - OPERATIONAL LIMITATIONS

2.1 Introduction .....	2-1
2.2 Weather Limitations.....	2-1
2.3 Fuel.....	2-2
2.4 Instrument Marking .....	2-2
2.5 Minimum Equipment .....	2-2
2.6 Admissible Damage .....	2-3
2.8 Maximum Envelope Temperature .....	2-4
2.9 Weight Range .....	2-4
2.10 Baskets Occupancy.....	2-6
2.11 Fitment Interchangeability .....	2-8
2.12 Other Manufacturers Equipment .....	2-12
2.13 Rate of Climb and Descent.....	2-12
2.14 Not Used .....	2-12
2.15 Deflation System Operation .....	2-12
2.16 Tethered Flight.....	2-12
2.17 Fuel Cylinders.....	2-13
2.18 Altitude .....	2-13
2.19 Power Lines .....	2-13
2.20 Additional Limitations for Baskets with Door .....	2-13
2.21 Additional Limitations for Passenger Seat.....	2-13
2.22 Additional Limitations for Removable Partitions.....	2-14
2.23 Additional Information for Collapsible Baskets K10C and K13C.....	2-14
2.24 Night Flying.....	2-14
2.25 Baskets with Lugs .....	2-14
2.26 Smoking .....	2-15
2.27 Oxygen supply.....	2-15

### SECTION 3 - EMERGENCY PROCEDURES

3.1 Introduction .....	3-1
3.2 Collision with Obstacle .....	3-2
3.3 Collision with Electric Power Lines .....	3-3
3.4 Midair Collision with Another Balloon .....	3-3
3.5 Damage to the Envelope in Flight.....	3-4
3.6 Non-standard Landing .....	3-4
3.7 Burner Failures .....	3-6
3.8 Fire .....	3-8
3.9 Gas Leak .....	3-9
3.10 Accidental Operation of SLV, SV, SLV (3 control lines), LV in Flight .....	3-9
3.11 Night Flying .....	3-9

## SECTION 4 - NORMAL PROCEDURES

4.1 Introduction.....	4-1
4.2 Flight Planning .....	4-1
4.3 Preparation, Assembling the Balloon and TAKE-OFF .....	4-2
4.4 In-Flight Procedures .....	4-16
4.5 Landing .....	4-19
4.6 Tethered Operations .....	4-23
4.7 Refuelling .....	4-24

## SECTION 5 - WEIGHT

5.1 Introduction.....	5-1
5.2 Loading Chart and Table .....	5-1
5.3 Flying in a Temperature Inversion .....	5-1
5.4 Sample Calculations.....	5-2
5.6 Loading Table .....	5-4

## SECTION 6 - BALLOON AND SYSTEMS DESCRIPTION

6.1 Introduction.....	6-1
6.2 Envelopes .....	6-1
6.3 Envelope Models .....	6-1
6.4 Envelope Deflation Systems and Equipment .....	6-2
6.5 Burner.....	6-9
6.6 Fuel Cylinder.....	6-14
6.7 Baskets .....	6-14
6.8 Instruments.....	6-18
6.9 Other Equipment.....	6-18

## SECTION 7 - BALLOON HANDLING, CARE AND MAINTENANCE

7.1 Introduction .....	7-1
7.2 Inspection Periods.....	7-1
7.3 Balloon Maintenance, Repairs and Alterations .....	7-1
7.4 Ground Handling and Road Transport.....	7-1
7.5 Cleaning and Care .....	7-2
7.6 Storage .....	7-2
7.7. Maintenance and Repairs Carried Out by the Pilot .....	7-2

## SECTION 8 - EQUIPMENT LIST

8.1 Table of Envelopes .....	8-1
8.2 Table of baskets .....	8-3
8.3 Table of Burners .....	8-5
8.4 Table of Fuel Cylinders.....	8-6
8.5 Table of Instruments.....	8-7

## SECTION 9 - APPENDICES

Appendix 1: Balloon Performance .....	9-1
Appendix 2: Basket Occupancy.....	9-2
Appendix 3: Kevlar Flying Cable Replacement.....	9-3
Appendix 4: Baskets up to s/n 399 .....	9-4
Appendix 5: Minimum Fuel Hose Radius .....	9-6
Appendix 6: Limits for baskets K32T or K40Y .....	9-7
Appendix 7: Location of temperature measuring equipment .....	9-8
Appendix 8: Additional Information for Collapsible Baskets K10C and K13C .....	9-11



## SECTION 1 - GENERAL

### 1.1 Introduction

The Hot Air Balloon Flight Manual (referred to as the Manual) has been prepared to provide pilots with information for the safe operation of below mentioned hot air balloons.

In addition to complying with this Manual a pilot must also comply with national regulations of both the country in which the balloon is registered and in which the balloon is being flown.

It is also pilot's responsibility to familiarize himself with all applicable documentations and supplements (the majority of these documents can be found on [www.kubicekballoons.com](http://www.kubicekballoons.com)).

### 1.2 Applicability

This manual in itself applies to hot air balloons of the BB type, manufactured by Kubíček Factory s.r.o.

If an appropriate supplement is inserted, the Manual also applies to the BB-S type, manufactured by Kubíček Factory s.r.o.

### 1.3 Certification Basis

The balloons have been approved by EASA under the following type certificates:

Balloon Type	Type Certificate No.
BB, BB-S	EASA.BA.003

### 1.4 Definitions and Abbreviations

#### Maximum Take-off Weight (MTOW)

MTOW is the maximum permissible total weight of the balloon and all its equipment at take-off including fuel, instruments, passengers and crew. It is also the maximum weight at which the balloon complies with airworthiness requirements. The MTOW does not include the weight of the lifting gas.

MTOW is also known as gross weight.

#### Reduced Maximum Take-off Weight (RMTOW)

RMTOW is the maximum permissible total weight of the balloon and all its equipment at take-off including fuel, instruments, passengers and crew deliberately decreased below the MTOW. The RMTOW must be approved by KB (see table on page II).

#### Applicable MTOW

Applicable MTOW is MTOW or RMTOW (if established, i.e. specified on page II). Exceeding the applicable MTOW renders the balloon non-airworthy.

#### Minimum Landing Weight (MLW)

MLW is the minimum permissible total weight of the balloon and all its equipment on landing including fuel, instruments, passengers and crew.

#### Surface windspeed

Surface wind speed is the wind speed 10 m (30 ft) above ground.

#### Crew

The crew are the persons participating in pre-flight preparation and packing of the balloon after landing.

## Chase Crew

The Chase Crew are the persons following the balloon in the chase vehicle.

## Passenger

A passenger is a person aboard the balloon not involved in controlling it.

## Total Permitted Lift

The total permitted lift is the maximum lift that the balloon is capable of with regard to ambient conditions.

## Abbreviations:

ISA - International Standard Atmosphere

KF - Kubíček Factory s.r.o.

DS - Deflation System

FDS - Fast Deflation System

LV - Lite Vent

SV - Smart Vent

SLV - Slide Vent

RV - Rotation Vent

RW - Red-White control line

MB - Main Burner

WB - Whisper Burner

PF - Pilot Flame

Throughout this Manual the terms mass and weight are interchangeable and have an identical meaning.

## The following definitions apply to Warnings, Cautions and Notes used in the Manual:

<b>WARNING</b>	Means that the non-observation of the corresponding procedure leads to an immediate or important degradation of the operational safety which may result in severe personal injury or death.
<b>CAUTION</b>	Means that the non-observation of the corresponding procedure leads to a minor or to a more or less long term degradation of the flight safety.
<b>NOTE</b>	Draws the attention to any special item not directly related to safety but which is important or unusual.

## 1.5 Descriptive Data

A hot air balloon is a very simple aircraft that derives its lift from the heated air. It consists of these major parts:

- envelope - the body containing the medium which provides the lift
- basket - the container suspended beneath the envelope for the carriage of the balloon occupants
- heater system - the system used to heat the air to provide the lifting means of the balloon. The system includes the heat source (burner), controls, fuel hoses, fuel cylinders, regulator, control valves and other related elements.

A complete description of the balloon, its components, systems and controls is given in chapter 6.

### 1.5.1 Envelopes

Envelopes are made either of polyester or nylon fabric. The load from the basket is transferred by vertical load tapes that join in the crown ring at the top of the envelope.

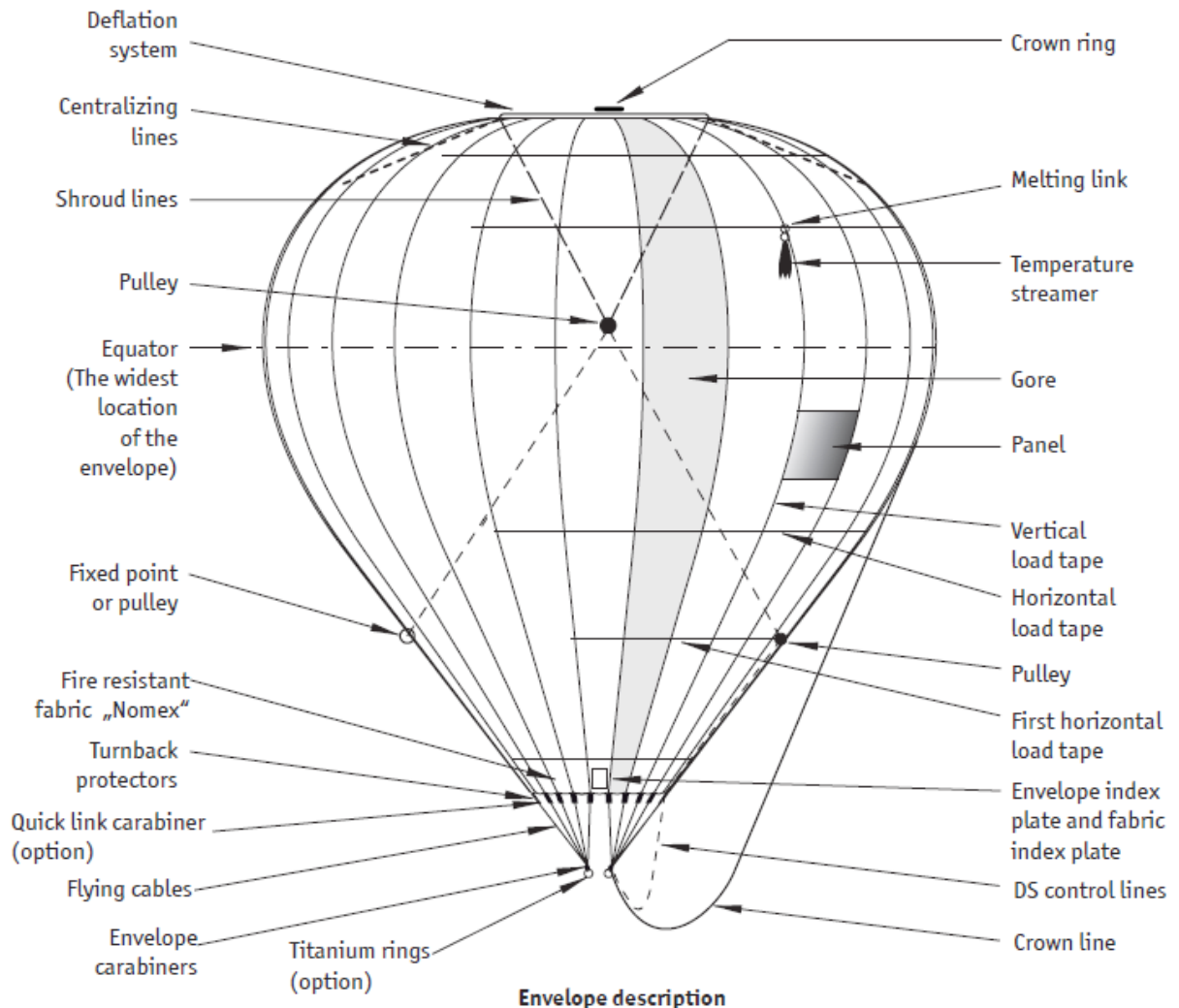

\*if titanium rings are used, they have to be fitted at all attachment points

\*\*quick link carabiners may be used for all or only for several flying wires

## 1.5.2 Baskets

Baskets have solid wooden or composite floors and the sides are woven from rattan or sewn from fabric. The top edges of the baskets are padded and covered by suede or leather. The weight of the basket and contents is carried by basket wires that run from the burner frame through the sides of the basket under the floor of the basket and back to the burner frame.

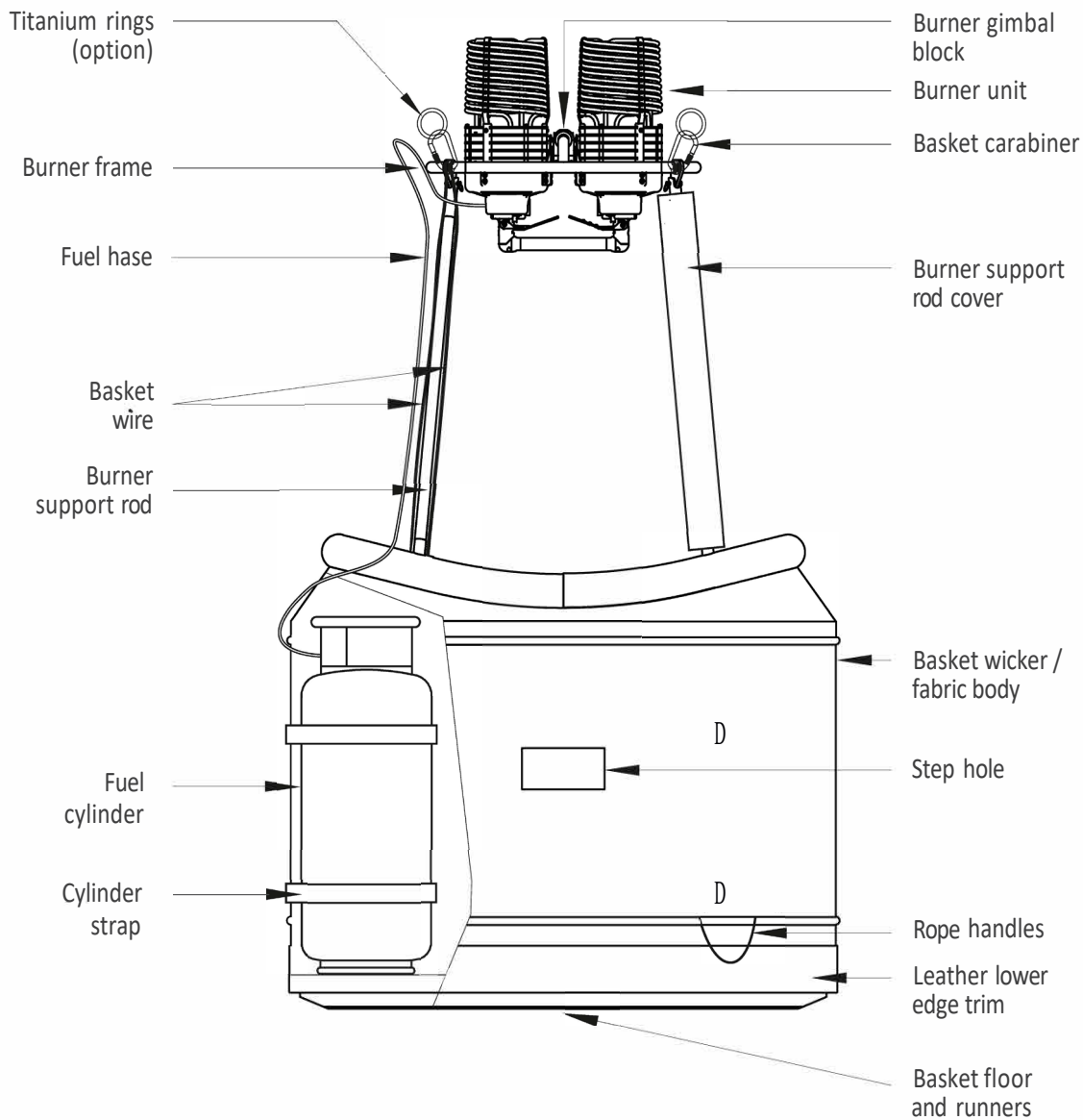

Bottom End Description

\*if titanium rings are used, they have to be fitted at all attachment points

<b>NOTE</b>	For descriptive data of the collapsible baskets K10C and K13C refer to Appendix 8.
-------------	--

### 1.5.3 Burners

Burners are the power source of a balloon. Fuel is taken from the fuel cylinders through fuel hoses and burnt to heat the air within the balloon envelope.

### 1.5.4 Fuel Cylinders

Fuel is stored in liquid form within fuel cylinders that are strapped within the basket. Each cylinder has a content gauge and a liquid take-off through which fuel is supplied to the burner. In addition master cylinders have a vapor take-off that supplies fuel to vapor pilot lights if required.

## 1.6 Use of Older Types of Equipment

Older types of baskets and burners not listed in this Manual may be used with new balloon envelopes provided the appropriate supplement to this Manual is used.

## 1.7 Night Flying

National rules for balloon night flying differ from country to country. Additional requirements or ones different from those stated in this Manual or in its supplement may apply.

## 1.8 General Operational Warnings

**WARNING** *Improper operation of the balloon may result in injury or death.*

### Power Lines

Power lines represent a major source of danger in ballooning. Their dangers cannot be overstated and must be treated with the greatest respect at all times. Some of the consequences of inadvertent power line contact include: 1. fire, 2. electrocution, 3. ruptures of the fuel system, 4. cutting of load cables, 5. severe damage to fabric. Each of these dangers or damage represents immediate life threatening situations and must be avoided.

### Licensed Pilots

The only licensed pilots may serve as a pilot in command. The pilot in command is responsible for the safe and proper conduct of all phases of flight. He or she must make the final decision on weather conditions, launch flight hazards, aircraft airworthiness, the execution of correct emergency procedures, the care of passengers, and landing site selection as well as any other situation which might effect the safe conclusion of flight. The pilot in command must have read and understand this manual thoroughly and comply with all applicable requirements. If in doubt, contact KB for advice.

### Fuel

LP gas or propane is a highly volatile fuel and as such must be treated with a great deal of respect at all times. Leaking LP gas in contact with skin can create severe burns. Liquid petroleum gas of which propane is the most common constituent, is heavier than air and as such tends to collect in low areas. It can pose a great danger of explosion. Similarly, any leak may be ignited by an ignition source at several feet distance. It is imperative that the potential for leaks be minimized, and when they occur, rapid and positive action must be taken to prevent a dangerous and possibly uncontrollable fire.

### Fire

Fire represents the most dangerous and immediate life threatening situation in flight. Due to limited means of extinguishing the fire, it is imperative that rapid steps be taken to land the aircraft immediately. Panic must be avoided and the pilot in command must control the action for all occupants. The option of jumping holds little chance for survival at heights much above 20 feet and further lessens the chance of survival of remaining occupants. Once the balloon has landed, all passengers and crew must exit the aircraft simultaneously to preclude the further flight with anyone left aboard.

## Limited Controllability

Limited controllability of a balloons in relation to other aircraft makes it mandatory that balloons remain clear of high density air traffic, high performance and military aircraft operating areas as well as marginal visibility conditions. Balloons produce faint and unreliable radar returns (unless equipped with a portable transponder) for both ground controllers and airborne radars leaving visual observation as the only means of locating and avoiding airborne balloons.

To fly in a controlled airspace or military areas requires a clearance from the responsible ATC/controller. If a transponder is required, the balloon must be equipped with it.

## Mid-air Collision

Avoid mid-air collision with any other balloon/aircraft at all times.

<b>NOTE</b>	<i>Envelope to envelope contact in approximate level flight creates low risk. Both pilots must take action to separate</i>
-------------	--

<b>WARNING</b>	<i>Envelope - basket contact creates high risk for both the balloons. Both pilots must take all possible measures to avoid such a collision. Both pilots must take action to separate</i>
----------------	---

## Fast Climb

The pilot must make sure that the sky above is clear before he starts climbing at a speed higher than 1 m/s (200 ft/min). Otherwise there is a serious danger of collision due to significant lag the balloon takes to get back to horizontal flight.

## Low Visibility

Flying at low visibility or with the possibility of restricted visibility, less than 1 NM, creates a high risk for the occupants and has to be avoided in any case.

## Balloon Modification

DO NOT, under any circumstances, attempt to bypass, shortcut, or eliminate any operational or safety feature designed into this balloon system.

<b>WARNING</b>	<i>The balloon must not be flown or modified without a valid approval of the appropriate national aviation authority.</i> <i>Hazardous conditions which could result in injury or death may result from:</i> <ul style="list-style-type: none"><li>• <i>the installation of non-approved parts or materials</i></li><li>• <i>modification of any part</i></li><li>• <i>improper repair procedures</i></li></ul>
----------------	--

Before undertaking any maintenance or modification not specifically documented in the Maintenance Manual, contact Kubíček Factory s.r.o. (see the last page of this Manual).

## SECTION 2 - OPERATIONAL LIMITATIONS

### 2.1 Introduction

This section specifies the operational limitations for the balloon and its standard equipment.

**WARNING** *The following limitations must be strictly adhered to, during the entire operation of the balloon.*

### 2.2 Weather Limitations

Maximum allowed surface wind speed during take-off and landing for:

	XR models M models	BB64Z and BB70Z with K32T or K32Y basket	BB92Z with K40Y, K40T, K40TTA, K50, K50TT and K50T- TA basket	BB 150P, BB184P	All other BB models
Free flight take-off (with quick release)	7.5 m/s (14.6 kts)	5.5 m/s (10.7 kts)	5.5 m/s (10.7 kts)	5.5 m/s (10.7 kts)	7.5 m/s (14.6 kts)
Free flight take-off (with quick release) at the reduced fabric strength *	5.0 m/s (10 kts)	5.5 m/s (10.7 kts)	5.5 m/s (10.7 kts)	5.5 m/s (10.7 kts)	7.5 m/s (14.6 kts)
Tethered operation	7.5 m/s (14.6 kts)	4.0 m/s (7.8 kts)	3.5 m/s (6.8 kts)	3.5 m/s (6.8 kts)	4.0 m/s (7.8 kts)

\*Reduced fabric strength means that the grab test was carried out according to the Maintenance Manual and has proven that the fabric strength is in the 10 - 13 kg range.

**WARNING** *Additional limitations apply when baskets K32T or K40Y fitted with burner frames without the symbol "S/N" before its serial number are used. See Appendix 6.*

**Balloons must not be flown or tethered if there is a thunderstorm, turbulence or another meteorological conditions (e.g. wind shear) that give raise to erratic or gusty wind in the vicinity of flight path.**

**WARNING** *Flights near cumulonimbus clouds must be rigorously avoided. These clouds often form thunderstorms. There may be dangerous turbulence and a risk of either the envelope being deflated or the balloon being carried up to altitudes where oxygen and temperatures are low.*

**The following issues related to weather need be considered, when planning a flight and choosing a launch site:**

**Turbulence / gusty  
wind**

Any wind gust make the balloon much more difficult to inflate. Wind gusts should be avoided on launch site especially when operating balloons of volume higher than 7000 m<sup>3</sup>.

**Maximum wind  
speed**

The values in the table above indicate maximum, not the mean wind speed. The gusts must be within the limits given by the table e.g. for mean speed 5 m/s (10 kts). A gust up to 2,5 m/s (5kts) is allowed, for mean speed 7.5 m/s (15 kts) no gust is allowed). Moreover, gusts above 5.1 m/s (10 kts) above mean speed are to be avoided.

**Takeoff weight**

It is much easier to operate in wind speed close to the maximum allowed values than the balloon loaded just above the MLW . It is highly recommended to load the balloon as much as possible when launching balloon under such conditions.

**Pilot experience**

The values from the table above show limitations of the balloon. The pilot must consider lowering of these limitation according to his or her experience and ability. The pilot-in-command should not fly the balloon if the surface winds are likely to be significantly stronger than winds in which he or she have previously flown. The experience with particular balloon size should also be considered. Higher wind landings should be practiced with an instructor until the pilot gains the necessary experience

<b>WARNING</b>	<i>Gusty winds or turbulence on launch site can cause tipping of the basket on the short side. This can cause a serious injury to passengers in the basket. The probability of a basket tipping is increased with a balloon less loaded. Take off in winds with a speed 5.0 m/s (10 kts) and higher makes the controllability of the balloon difficult.</i>
----------------	---

## 2.3 Fuel

The approved fuel is either propane or a propane-butane mix (LPG).

Maximum admissible fuel pressure: **12 bar (174 psi)**

When pressurising fuel cylinders with nitrogen, care must be taken not to exceed **10 bar (145 psi)**.

**Minimum admissible fuel pressure: 3 bar (44 psi)**

<b>WARNING</b>	<i>Fuel cylinders must not be heated by a direct flame or left in direct sunshine or overfilled.</i>
----------------	--

<b>CAUTION</b>	<i>Care should be taken if the fuel pressure is below 5.5bar (80 psi) which reduces heat output of the burner. At low fuel pressure a balloon will be less responsive. The bigger the envelope the stronger this effect is. It is advisable to heat with both main and whisper burner to compensate for the decreased heat output.</i>
----------------	--

<b>NOTE</b>	<i>The pressure in a cylinder will be reduced if it has been pressurized with nitrogen as the contents of the cylinder is reduced. Pilot flame failure may occur when nitrogen is used.</i>
-------------	---

At high burner pressures the burner flame will be longer than usual. In smaller envelopes (up to 3400 m<sup>3</sup>) care must be taken to avoid damage to the control lines if the burner was operated with longer bursts.

### Minimum Fuel Quantity

The minimum number of full fuel cylinders required at take-off:

1-unit burner	2 cylinders
2-unit burner	2 cylinders
3-unit burner	3 cylinders
4-unit burner	4 cylinders

## 2.4 Instrument Marking

Instrument markings and color code meanings are shown for the burner pressure gauge.

Red Radial Line	Yellow Arc	Green Arc	Yellow Arc	Red Radial Line
Lower Limit	Significant Power Decrease	Normal Operation	Significant Flame Length Increase	Upper Limit
3 bar (44 psi)	3 - 4 bar (44 - 58 psi)	<b>4 -11 bar</b> (58 - 160 psi)	11 -12 bar (160 - 174 psi)	12 bar (174 psi)

## 2.5 Minimum Equipment

The following list of equipment must be carried on every flight:

- Altimeter and variometer
- Envelope temperature indicator. This may be either one that gives a direct reading or one that gives a warning signal (temperature streamer attached with a melting link).
- Two sources of ignition. Matches or ignitor or similar source in addition to piezo ignitors built into the burner.
- Fire extinguisher.
- Fire blanket.



- Drop line of length at least 25m (82 ft).
- An accurate time piece displaying time in hours, minutes and seconds.
- Items used to determine drift direction (e.g. compass, map...). Electronic map is acceptable when there is backup device available.
- First aid kit.
- Quick release.
- Protective gloves for the pilot and crew.
- Oxygen supply (supplemental oxygen storage and dispensing apparatus) for high altitudes flights - see 2.27.

**WARNING**

*Prolonged flight above 3 000m (10 000 ft) MSL without oxygen may result in oxygen deficiencies causing hypoxia. Symptoms are loss of coordination, dizziness, blurred vision, or an euphoric feeling. Hypoxia may eventually cause unconsciousness and death.*

**WARNING**

*National regulations may require additional equipment based on conditions of the intended flight!*

**WARNING**

*All required minimum equipment must be of proper and quality design and must function correctly!*

**CAUTION**

*If the maximum permitted envelope temperature is lower than 124°C (255°F) the thermometer is to be used for monitoring envelope fabric temperature instead of temperature streamer.*

## 2.6 Admissible Damage

- No damage is permitted to the burner or fuel system, and no damage is permitted to the load tapes or to any load bearing part of the envelope or basket suspension system.
- Damage to the fabric below the first horizontal load tape (except D, ED types) or within 4 m (13 ft) of the nomex (D, ED type) is permitted.
- Damage to fabric above the previously described location is limited to small holes or tears of no more than 5mm (1/4 in) in any direction. The integrity of any panel must not be affected by the holes or tears .
- Any damage exceeding the above limits must be repaired prior the next flight according to the instructions given by the Kubíček Factory Maintenance Manual.

**WARNING**

*Any damage to the fabric weakens the fabric's resistance to tear and causes localized heating of the fabric around that damage. Damage exceeding those listed above increases the potential of propagating a tear or hole and is unacceptable for flight.*

- The balloon must not be flown without the burner support rods.
- The fuel quantity gauge must function correctly at least on the minimum number of full fuel cylinders required at take-off (see chapter 2.3).
- The balloon fitted with Sirius burner can be flown only when both pilot lights are fully functional.

### Applicable for collapsible baskets K10C and K13C only

- The balloon cannot be flown if even one of the side straps of the cylinder harness is torn or frayed through more than 15 % of the width.  
If there is such a damage to the middle strap, the cylinder harness must not be used for securing any fuel cylinder.
- No scores to flexible parts of the rods deeper than 2 mm.
- No damage or cut through both layers of the fabric sidewall greater than 5 cm (crack length). Maximum 2 such tears on one side of the basket.

## 2.7 Crew

Minimum crew: One pilot holding a valid appropriate license.

Maximum basket occupancy: See 2.9 and 2.10 below.

## 2.8 Maximum Envelope Temperature

The maximum allowable temperature in the envelope:

- **124°C (255°F)** for the envelopes entirely made from Polyester fabric
- **specified on the Envelope fabric index plate** for other fabrics

The envelope fabric index plate is located at the envelope mouth.

<b>CAUTION</b>	<i>Operating above these limits can cause a rapid decrease of the fabric strength and porosity of the envelope fabric.</i>
----------------	--

## 2.9 Weight Range

The actual weight of the balloon must be kept between the following limits during the entire flight:

Upper limit - the lowest of these values:	Lower limit
<b>MTOW</b> or, <b>RMTOW</b> (if established), or <b>Maximum balloon lifting capacity</b> established according to chapter 5 of this Manual	<b>MLW</b>

<b>CAUTION</b>	<i>If a balloon is flown very lightly loaded then there will be a relatively low pressure in the envelope and it will distort easily in either light turbulence or when passing through wind shear in the climb or descent. This mainly concerns smaller balloons.</i>
----------------	--

<b>CAUTION</b>	<i>Flying at temperatures 115°C and higher in the envelope results in increased fuel consumption.</i>
----------------	---

### RMTOW limitations

The owner/operator of a balloon may, by agreement with KB, designate a RMTOW for a specific balloon which is lower than the MTOW for the specific balloon model. This RMTOW must not be less than 55% of the original MTOW or the sum of weight of a complete balloon with a minimum crew and a minimum equipment, whichever is greater. The RMTOW, if applied, is specified on page II of this Manual.

The RMTOW may be revised at any time by agreement with KB. Any revision becomes valid when the revised figure is entered on page II of this Manual and countersigned by KB.

**Envelope Weight Limits:**

Envelope Model	Max. Take-off Weight (MTOW)		Min. Landing Weight (MLW)	
	[kg]	[lb]	[kg]	[lb]
BB9, BB9E, BB9EF	295	650	135	297
BB12, BB12E, BB12EF	385	849	180	397
BB14XR	420	926	210	463
BB16, BB16E, BB16EF, BB16XR	470	1 036	230	507
BB17GP, BB17XR	495	1 090	250	551
BB18E	550	1 211	255	562
BB18XR	570	1256	255	562
BB20, BB20E, BB20ED	630	1 389	280	617
BB20GP, BB20XR	730	1 609	280	617
BB22E, BB22ED, BB22M	680	1 498	300	661
BB22, BB22D, BB22N, BB22Z	730	1 609	300	661
BB22XR	780	1 720	300	661
BB26E, BB26ED, BB26M	730	1 609	340	749
BB26, BB26D, BB26N, BB26Z, BB26XR	840	1 852	340	749
BB30E, BB30ED, BB30M	840	1 852	340	749
BB30D, BB30N, BB30Z, BB30XR	945	2 083	410	904
BB34E, BB34ED	945	2 083	455	1 003
BB34D, BB34Z	1 040	2 291	455	1 003
BB37D, BB37N, BB37Z	1 150	2 535	500	1 102
BB40D, BB40Z	1 310	2 885	580	1 278
BB42D, BB42Z	1 410	3 109	630	1 389
BB45D, BB45N, BB45Z	1 520	3 351	670	1 477
BB51D, BB51Z	1 690	3 726	780	1 720
BB60D, BB60N, BB60Z	1 940	4 277	930	2 050
BB64Z	2 100	4 626	1 000	2 203
BB70D, BB70Z	2 300	5 071	1 060	2 337
BB78Z	2 600	5 727	1 200	2 643
BB85D, BB85Z	2 820	6 217	1 350	2 976
BB92Z	3 000	6 608	1 450	3 194
BB100D, BB100Z	3 200	7 055	1 600	3 527
BB105P	3 500	7 709	1 700	3 744
BB106P	3 500	7 709	1 700	3 744
BB113P	3 600	7 930	1 800	3 965
BB120P	3 700	8 150	1 850	4 075
BB130P	4 200	9 251	1 950	4 295
BB142P	4 500	9 912	2 000	4 405
BB150P	4 800	10 582	2 100	4 630
BB184P	5 095	11 233	2 500	5 512

## 2.10 Baskets Occupancy

Each occupant within a basket must be provided with reasonable space for comfort during the flight and safety on landing. The relative mass and size of the passengers must be taken in account. Details are given in Appendix 2.

**WARNING** *Failing to provide a reasonable space to every occupant significantly increases a risk of serious injury!*

There must be at least one rope handle in reach for each passenger.

The pilot must have adequate space to access and operate all fuel systems, control lines and any other balloon control.

**The limitations in two tables below apply to baskets of s/n 400 and higher. The appropriate data for baskets up to s/n 399 are stated in Appendix 4 of this Manual.**

### Baskets Limitations:

Basket	Minimum floor area		Load capacity		Max. Number of Occupants
	[m <sup>2</sup> ]	[sq. ft]	[kg]	[lb]	
K7	0.72	7.8	450	991	2
K10	0.99	10.7	600	1 322	3
K10C	0.89	9.6	455	1 003	2
K10S	1.00	10.7	455	1 003	3
K11	1.14	12.2	650	1 432	3
K12, K12A	1.35	14.5	700	1 542	4
K13	1.45	15.6	700	1 542	4
K13C	1.14	12.3	550	1 210	3
K13S	1,20	12,9	550	1 210	3
K14	1.57	16.9	800	1 764	5
K15	1.57	16.9	800	1 764	5
K16	1.68	18.1	900	1 982	5
K17	1.68	18.1	900	1 982	5
K18	1.80	19.4	950	2 093	6
K19	1.80	19.4	950	2 093	6
K19L	1.88	20.2	950	2 093	6
K22	2.25	24.2	980	2 159	8
K23	2.25	24.2	980	2 159	6
K25P	2.62	28.2	1 000	2 203	8
K28	3.52	37.9	1 100	2 423	8
K28H	3.76	40.5	1 100	2 423	8
K30PP	3.25	35.0	1 100	2 423	10
K32Y, K32T	3.84	41.3	1 100	2 423	10
K32TT	4.00	43.1	1 100	2 423	10
K40Y, K40T	4.32	46.5	1 200	2 643	12
K40TTA	4.32	46.5	1 200	2 643	12
K50	4.80	51.7	1 400	3 084	14
K50TT	4.80	51.7	1 400	3 084	14
K50TTA	4.80	51.7	1 400	3 084	14
K50TT8	4.80	51.7	1 400	3 084	14
K55X	5.52	59.4	1 700	3 748	16
K55TTA	5.52	59.4	1 700	3 748	16

Basket	Minimum floor area		Load capacity		Max. Number of Occupants
	[m <sup>2</sup> ]	[sq. ft]	[kg]	[lb]	
K58HH	6.08	65.4	1 400	3 084	14
K60	6.08	65.4	1 800	3 965	18
K60X	6.24	67.2	1 800	3 965	18
K65TTA	6.56	70.6	2 500	5 512	20
K70	7.04	75.8	3 000	6 608	22
K70TTA	7.04	75.8	3 000	6 608	22
K80	7.68	82.7	3 400	7 489	26
K85	8.32 (8.80 option)	89.6 (94.7 option)	3 400	7 489	26
K90	8.32 (8.80 option)	89.6 (94.7 option)	3 400	7 489	26
K100	9.76	105.1	4 000	8 811	30
K110	10.56	113.7	4 000	8 811	34

The basket load capacity is the maximum weight the basket is allowed to carry. The weight limitation for the entire balloon remains unaffected.

#### Occupancy of Compartmentalized Baskets:

Basket	Max.Occupancy of Compartmentalized Baskets		Passenger Compartment Floor Area		Pilot Compartment Floor Area	
	Passenger Compartment.	Pilot Compartment.	[m <sup>2</sup> ]	[sq. ft]	[m <sup>2</sup> ]	[sq. ft]
K25P	6	pilot + 1	1.66	17.90	0.96	10.3
K28	3	pilot + 1	1.1 (variant T) 1.2 (variant Y)	11.85 (variant T) 12.9 (variant Y)	1.32 (variant T) 1.12 (variant Y)	14.2 (variant T) 12.1 (variant Y)
K28H	2	pilot + 1	0.81	8.77	1.32	14.2
K30PP	4	pilot + 1	1.15	12.35	0.96	10.3
K32T	4	pilot + 1	1.26	13.55	1.32	14.2
K32Y	4	pilot + 1	1.36	14.60	1.12	12.1
K32TT	2	pilot + 1	0.67	7.23	1.32	14.2
K40T	5	pilot + 1	1.50	16.15	1.32	14.2
K40Y	5	pilot + 1	1.60	17.20	1.12	12.1
K40TTA	right: 2 left: 3	pilot + 1	right: 0.55 left: 0.83	right: 5.92 left: 8.93	1.32	14.2
K50	6	pilot + 1	1.74 (variant T) 1.84 (variant Y)	18.75 (variant T) 19.8 (variant Y)	1.32 (variant T) 1.12 (variant Y)	14.2 (variant T) 12.0 (variant Y)
K50TT	3	pilot + 1	0.87	9.38	1.32	14.2
K50TTA	right: 2 left: 4	pilot + 1	right: 0.54 left: 1.08	right: 5.81 left: 11.63	1.32	14.2
K50TT8	3	pilot + 1	0.87	9.38	1.32	14.2
K55X	outer: 3 middle: 4	pilot + 1	outer: 0.81 middle: 1.16	outer: 8.76 middle: 12.51	1.32	14.2
K55TTA	right: 3 left: 4	pilot + 1	right: 0.84 left: 1.13	right: 9.04 left: 12.16	1.32	14.2
K58HH	2	pilot + 1	0.79	8.53	1.32	14.2
K60X	4	pilot + 1	1.23	13.25	1.32	14.2

Basket	Max.Occupancy of Compartmentalized Baskets		Passenger Compartment Floor Area		Pilot Compartment Floor Area	
	Passenger Compartment.	Pilot Compartment.	[m <sup>2</sup> ]	[sq. ft]	[m <sup>2</sup> ]	[sq. ft]
K60	4	pilot + 1	1.19	12.80	1.32	14.2
K65TTA	right: 4 left: 5	pilot + 1	right: 1.12 left: 1.35	right: 12.06 left: 14.53	1.32	14.2
K70	5	pilot + 1	1.43	15.40	1.32	14.2
K70TTA	right: 4 left: 6	pilot + 1	right: 1.08 left: 1.62	right: 11.63 left: 17.44	1.32	14.2
K80	6	pilot + 1	1.59	17.13	1.32	14.2
K85	6	pilot + 1	1.75 (1.74 option)	18.85 (18.73 option)	1.32 (1.84 option)	14.2 (19.8 option)
K90	outer: 2 inner: 4	pilot + 1	outer: 0.58 middle: 1.05	outer: 6.24 middle: 11.3	1.32 (1.84 option)	14.2 (19.8 option)
K100	outer: 3 inner: 4	pilot + 1	outer: 0.76 middle: 1.05	outer: 8.18 middle: 11.3	1.84	19.8
K110	4	pilot + 1	1.05	11.30	1.84	19.8

**NOTE** The number of fuel cylinders is to be established according to instructions given in Appendix 2. A simplified general practice for passenger compartments is: "one cylinder in - one person out".

## 2.11 Fitment Interchangeability

Approved Combinations of BB Envelopes and Baskets:

Envelope model	Basket model																			
	K7	K10S	K10C	K10	K11, K12, K12A	K13, K13S	K13C	K14, K15, K16, K17, K18 K19, K19L, K22	K23	K25P, K28, K28H, K30PP	K32T, K32Y	K32TT	K40T, K40Y, K40TTA, K50, K50TTA	K50TT	K50TT8, K55X, K55TTA, K58HH	K60, K60X	K65TTA	K70, K70TTA	K80	K85, K90, K100, K110
BB9, BB9E, BB9EF			RV				RV													
BB12, BB12E, BB12EF			RV				RV													
BB14XR			RV				RV													
BB16, BB16E, BB16EF, BB16XR			RV				RV													
BB17XR			RV				RV													
BB17GP			RV				RV													
BB18E			RV				RV													
BB18XR			RV				RV													
BB20, BB20ED, BB20E, BB20GP			RV				RV													
BB20XR			RV				RV													
BB22, BB22D, B22ED, BB22E, BB22N, BB22Z, BB22XR, BB22M			RV				RV													

Envelope model	Basket model																			
	K7	K10S	K10C	K10	K11,K12,K12A	K13, K13S	K13C	K14,K15,K16,K17,K18 K19,K19L,K22	K23	K25P, K28, K28H, K30PP	K32T, K32Y	K32TT	K40T,K40Y, K40TTA, K50,K50TTA	K50TT	K50TT8, K55X, K55TTA, K58HH	K60, K60X	K65TTA	K70, K70TTA	K80	K85, K90, K100, K110
BB26, BB26D, BB26ED, BB26E, BB26N, BB26Z BB26XR, BB26M			RV				RV													
BB30D, BB30ED, BB30E, BB30N, BB30Z, BB30XR, BB30M			RV				RV													
BB34D, BB34ED, BB34E, BB34Z			RV				RV													
BB37D, BB37N, BB37Z			RV				RV		RV	RV										
BB40D, BB40Z							RV		RV	RV										
BB42D, BB42Z							RV		RV	RV										
BB45D, BB45N, BB45Z							RV		RV	RV	RV	RV	RV	RV						
BB51D, BB51Z									RV	RV	RV	RV	RV	RV						
BB60D, BB60N, BB60Z									RV	RV	RV	RV	RV	RV	RV	RV	RV	RV		
BB64Z										RV	RV	RV	RV	RV	RV	RV	RV	RV		
BB70D, BB70Z										RV	RV	RV	RV	RV	RV	RV	RV	RV	RV	
BB78Z											RV	RV	RV	RV	RV	RV	RV	RV	RV	
BB85D, BB85Z											RV	RV	RV	RV	RV	RV	RV	RV	RV	
BB92Z												RV		RV	RV	RV	RV	RV	RV	
BB100D, BB100Z														RV	RV	RV	RV	RV	RV	RV
BB105P															RV	RV	RV	RV	RV	RV
BB106P															RV	RV	RV	RV	RV	RV
BB113P															RV	RV	RV	RV	RV	RV
BB120P															RV	RV	RV	RV	RV	RV
BB130P															RV	RV	RV	RV	RV	RV
BB142P															RV	RV	RV	RV	RV	RV
BB150P																		RV <sup>40</sup>	RV <sup>40</sup>	RV <sup>40</sup>
BB184P																		RV <sup>40</sup>	RV <sup>40</sup>	RV <sup>40</sup>

**Explanation:**

 = approved combination

 RV = rotation vent must be fitted

 40 = only the 40 kN carabiners may be used for connecting the envelope flying wires and the basket flying wires to the burner frame

**WARNING**

Ensure a correct burner frame is used for selected approved combination! Limitations for burner frames are listed in a table below (Approved Combinations of Burner Frames and BB Envelopes).

## Approved Combinations of Burner Frames and BB Envelopes:

Burner frame model	Maximum allowed envelope volume	
	max. wind speed 7.5 m/s	max. wind speed 5.5 m/s
Sirius	4000 m <sup>3</sup>	N/A
Basic / Vario	4500 m <sup>3</sup>	N/A
K23	4500 m <sup>3</sup>	N/A
K25P	6000 m <sup>3</sup>	N/A
K30PP	7000 m <sup>3</sup>	N/A
K32T	6000 m <sup>3</sup>	7000 m <sup>3</sup>
K32TT	7000 m <sup>3</sup>	N/A
K50*	8500 m <sup>3</sup>	9200 m <sup>3</sup>
K50TT	8500 m <sup>3</sup>	N/A
K60	12000 m <sup>3</sup>	N/A
K60 STRONG	14200 m <sup>3</sup>	N/A
K60X	14200 m <sup>3</sup>	N/A
K100	14200 m <sup>3</sup>	N/A
K100 STRONG	14200 m <sup>3</sup>	18400 m <sup>3</sup>

### Explanation:

\* = Only the burner frame with the symbol S/N before the serial number may be used with envelopes of volume from 7800 to 9200 m<sup>3</sup>.

**NOTE** *The maximum approved combination of envelope-basket and maximum allowed envelope size for the corresponding burner frame may differ. That is because each burner frame may be used with different baskets. Always check the envelope-basket combinations table!*

**NOTE** *Some burner frame types might get mistaken for another type due to their same dimensions (e.g. K32TT and K50TT). To differentiate them, these models are marked with the maximum acceptable envelope volume (see the picture below). Make sure the correct burner frame is used.*

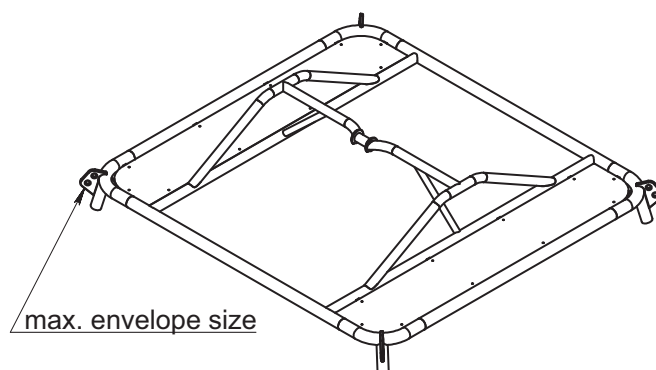



## Approved Combinations of BB Envelopes and Burners:

Envelope model							
	KOMET DUO up to 104	KOMET DUO 105+	KOMET TRIO	SIRIUS	IGNIS 2 units	IGNIS 3 units	IGNIS 4 units
BB9, BB9E, BB9EF							
BB12, BB12E, BB12EF							
BB14XR							
BB16, BB16E, BB16EF, BB16XR							
BB17XR							
BB17GP							
BB18E, BB18XR							
BB20, BB20ED, BB20E, BB20GP, BB20XR							
BB22, BB22D, BB22ED, BB22E, BB22N, BB22Z, BB22XR, BB22M							
BB26, BB26D, BB26ED, BB26E, BB26N, BB26Z, BB26XR, BB26M							
BB30D, BB30ED, BB30E, BB30N, BB30Z, BB30XR, BB30M							
BB34D, BB34ED, BB34E, BB34Z							
BB37D, BB37N, BB37Z							
BB40D, BB40Z							
BB42D, BB42Z							
BB45D, BB45N, BB45Z							
BB51D, BB51Z							
BB60D, BB60N, BB60Z							
BB64Z					*		
BB70D, BB70Z					*		
BB78Z					*		
BB85D, BB85Z							
BB92Z						*	
BB100D, BB100Z						*	
BB105P						*	
BB106P							
BB113P							
BB120P							
BB130P							
BB142P							
BB150P							
BB184P							

## Explanation:

 = approved combination

 = applicable for the Ignis burners of s/n 516 and higher

## 2.12 Other Manufacturers Equipment

Baskets and burners from certain other manufacturer may be combined with Kubicek envelopes. If so, the instructions given in the bulletin BB/22b-1 must be observed.

Moreover, any bulletin or airworthiness directive issued and applicable for the parts used as a replacement for Kubicek part shall be considered mandatory for compliance of the balloon according to the same terms that the bulletin or airworthiness directive is required for compliance of the respective non-Kubicek parts

## 2.13 Rate of Climb and Descent

### Vertical Speed Limitations:

Model	Maximum Rate of Climb		Maximum Rate of Descent	
	[m/s]	[ft/min]	[m/s]	[ft/min]
All BB models except below mentioned	4.0	800	6.5	1 300
BB9, BB9E, BB9EF	4.0	800	5.0	1 000
GP models, M models	6.0	1 200	6.5	1 300
XR models	9.0	1 800	9.0	1 800
XR and M models at the reduced fabric strength*	5.0	1 000	5.0	1 000

\*Reduced fabric strength means the grab test carried out according to the Maintenance Manual has proven the fabric strength in the range 10 - 13 kg.

In case the envelope fabric strength is reduced, this is indicated in the balloon logbook and on the Envelope fabric index plate (if applicable).

## 2.14 Not Used

## 2.15 Deflation System Operation

### Landing deflation

Except in an emergency, opening the Slide Vent, Smart Vent, Lite Vent or Rip Panel with the red line is prohibited if the underside of the basket is higher than 2 m (6.5 ft) above the ground.

### Inflight venting

Inflight venting is prohibited:

- if the mouth of the envelope deforms
- during cool descent
- during rapid climb (when the balloon is near or above its speed limitation).

The envelope must be allowed to reinflate fully before subsequent operation of the deflation system.

<b>NOTE</b>	<i>Good sign of the cool descent is when the balloon rotates by itself or the envelope fabric in the mouth is not tight.</i>
-------------	--

<b>WARNING</b>	<i>Improper use of the deflation system can result in loss of control over the balloon and lead to serious or even fatal injuries.</i>
----------------	--

The Parachute Valve, when used for controlled release of hot air during the flight, must not be held open for periods longer than 3 seconds.

## 2.16 Tethered Flight

Balloons must not be tethered in conditions prohibited in chapter 2.2 Weather Limitations. The maximum height for tethered flight is 30 m (100 ft) between the underside of the basket and the ground.

For baskets K14, K28, K28H, K30PP, K32Y, K32TT, K40TTA, K50TT, K50TT8, K50TTA, K55X, K55TTA, K58H, K60X, K65TTA, K70, K70TTA, K80, K85, K90, K100 and K110 an approved set of tethering components must be used.

**Weight limitations for tethered flight:**

Upper limit - the lowest of these values:	Lower limit
<b>75% of the MTOW or, RMTOW (if established), or Maximum balloon lifting capacity</b> established according to chapter 5 of this Manual	<b>MLW</b>

**WARNING** *The limitations stated above are based on the balloon structure. In every case the pilot must consider his skills, experience and actual condition when making decision about tethered flight.*

**NOTE** *In some countries tethered flights of a hot-air balloon may be prohibited by the local aviation authority. Balloons may not be used as a platform for bungee jumping.*

**2.17 Fuel Cylinders**

All fuel cylinders must be fitted with an outer water resistant protective layer. The limitations for material and thickness of the protective layer established by the cylinder manufacturer must be observed.

Each fuel cylinder must be secured inside of the basket with at least 2 cylinder straps or with 1 cylinder harness of an approved design (applicable for collapsible baskets K10C and K13C only).

**WARNING** *No part of any fuel cylinder may overlap the upper edge of the basket.*

**WARNING** *Each of 4 cylinder harnesses (K10C and K13C baskets only) must be tightened even when there is no fuel cylinder to secure.*

**WARNING** *Leather straps must not be used.*

**2.18 Altitude**

Maximum permissible operating altitude is the altitude at which the burner fails to maintain ignition or the altitude at which the maximum allowable envelope temperature is reached, whichever happens first.

For flights above 3 000 m (10 000 ft) of pressure altitude, flight crew and passenger oxygen must be used according to the applicable aviation requirements - details are given in chapter 2.27 Oxygen supply. National air space designations and limitations must also be followed by the pilot.

**2.19 Power Lines**

**WARNING** *Balloon must not be flown into contact with power lines!  
When crossing power lines, the balloon must be in level flight or ascending at a safe height above them.*

**2.20 Additional Limitations for Baskets with Door**

The basket fitted with the door or the passenger seat installed must only be flown under an envelope fitted with a Rotation Vent.

**WARNING** *Door hinge pin(s) or door zippers (for K10C and K13C baskets) must be secured during the entire flight.  
The door must be closed during the entire flight.*

**2.21 Additional Limitations for Passenger Seat**

The seat, trestle and attachment system must not be damaged.

The passenger in the seat must be seated and wear the harness during the entire flight.

## 2.22 Additional Limitations for Removable Partitions

- The partitions must be installed prior to balloon inflation and may not be moved or adjusted during inflation or in-flight.
- No more than 6 persons may be carried in one basket compartment or open space. For the K32TT basket the maximum occupancy of the “compound” compartment made by removing the central partitions is 4 persons. For the K25P basket this number is 8, i.e. maximum occupancy is reduced to 6.
- Each passenger must have within reach at least one hand hold in his or her compartment.
- Maximum two persons may stand behind each other during landing in “compound” compartment.
- A minimum floor area for each person of 0.25m<sup>2</sup> must be maintained regardless of arrangement of a partition.
- The fuel cells may not be strapped to the non-woven partitions of the pilot compartment.
- The non-woven pilot compartment partitions are not considered as dividing the space. The maximum number of persons in neighbouring compartments need to be established as for an undivided compartment.
- MTOW and MLW remain applicable.
- Transversal pilot compartment, woven or non-woven, must always be used for flight.

**WARNING** *No operation with the pilot compartment partition removed is allowed.*

**CAUTION** *Removing of partitions results in a lower maximum occupancy of the basket. Pay attention to observing the MLW and, mainly at “TT”, baskets to an even distribution of weight.*

## 2.23 Additional Information for Collapsible Baskets K10C and K13C

During the inflation and the entire flight:

- steps on both sides must be in locked position and secured by both red velcros;
- all 4 rods must be secured by locking pin;
- protection plates of an approved design must be placed on the landing side;
- all straps of the equipment pocket must be fully tightened;
- when loading fuel cylinders in the basket, two corners on the landing side must be used first;
- all cylinder harnesses must be fully tightened;
- upper, lower and door zipper sliders of the fabric sidewalls must be secured by carabiners;
- fuel hose leading along the short side of the basket must go through the tunnel on the sidewall.

**WARNING** *The fuel hoses must not be stepped on as this can cause their damage resulting in serious injury/death.*

**NOTE** *More information and detailed pictures of the collapsible baskets K10C and K13C are available in Appendix 8.*

**CAUTION** *Use primarily the door or steps on the short sides to board/load the basket. Fuel cylinders can be loaded over the top of the basket when steps and rods are secured.*

## 2.24 Night Flying

### Minimum Equipment

Additional compulsory equipment for night flights:

- Night lighting equipment complying with applicable national requirements.
- Two independent, not hand-held, portable lights for illumination of instruments and equipment (e.g. head-lamp) with a minimum lighting distance of 60 m.

## 2.25 Baskets with Lugs

The maximum wind speed for take-off using the quick release attached to the basket lugs is **4.0 m/s (7.8 kts)**.

## 2.26 Smoking

Smoking in the balloon and within 30 m (100 ft) is prohibited.

## 2.27 Oxygen supply

The oxygen supply is required when

- all flight crew members engaged in performing duties essential to the safe operation of a balloon use supplemental oxygen for any period in excess of 30 minutes when the pressure altitude will be between 3 000m (10 000 ft) and 4 000m (13 000 ft); and
- all occupants use supplemental oxygen for any period that the pressure altitude will be above 4 000m (13 000 ft).
- National regulations must also be observed.

**intentionally left blank**

## SECTION 3 - EMERGENCY PROCEDURES

### 3.1 Introduction

This section specifies the actions of the pilot in case of emergency situations that may occur during flight. An emergency situation creates additional stress and requires a proper distribution of attention between flying the balloon and dealing with the emergency.

Every person piloting a Kubicek balloon must be thoroughly familiar with these emergency procedures. Be sure to have them studied, understood and reviewed regularly. Should an emergency arise, follow the instructions given in this section.

**WARNING** *Emergency situations of all kinds shall be prevented by all possible means.*

**WARNING** *Failure to respond quickly and effectively to the emergencies documented in this section can result in injury or even death of passengers, others persons or the pilot.*

**WARNING** *SAFETY OF THE PEOPLE IS THE PRIMARY CONCERN!  
Safety of the passengers and persons on the ground are the primary concern of the pilot in an emergency. Material damage is of secondary concern.*

#### 3.1.1 Passenger Emergency Positions for Landing or Collision

**WARNING** *The correct positioning of persons in the basket is important for minimising the risk of injury!*

##### Fast landing or collision

- Stay low in the basket and bend knees. Heads always below the upper rim of the basket.
- Stow all objects (cameras etc.), hold on the rope handles with both hands.
- Place as many passengers as possible to the rear side of the basket
- In open baskets heavier persons need to be placed first in the direction of flight. Sideways position is the most favourable but difficult to achieve due to limited space. If the sideways position is not possible, the persons placed first should also be oriented backwards to the direction of flight.
- In case of a passenger travelling inside of the pilot's compartment - use the rope handle for securing. It is allowed to use rope handle with one hand and the rim of the fuel tank with the other hand, if this would offer more stable position (considering the number and distribution of the fuel tanks and other factors).

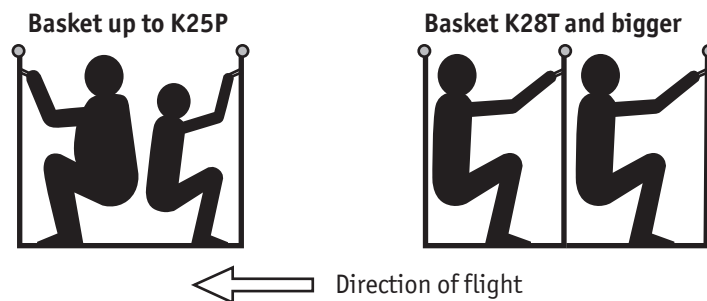

## Hard landing

- Stand with legs slightly bent for damping impact.
- Stow all objects (cameras etc.), hold on the rope handles with both hands.
- Keep both feet fully on the floor to distribute impact onto both ankles and to prevent a dangerous torque.

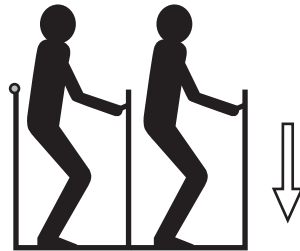

Direction of flight

## 3.2 Collision with Obstacle

### 3.2.1 Decision: Landing or Climbing

With an obstacle in the flight path the pilot must decide soon enough about the solution: landing or climbing over the obstacle. Landing is advisable and safer. Climbing is preferred only when the pilot is sure the obstacle can be safely overflown.

### 3.2.2 Emergency Climb

- |  |
|--|
| <ol style="list-style-type: none"><li>1. Once the decision to climb over the obstacle is made, do not change the decision.</li><li>2. Heat as much as possible:<ul style="list-style-type: none"><li>• On a single burner open the main blast valve from one fuel supply and the whisper burner from the second fuel supply.</li><li>• On a double, triple or quad burner each burner should use its own fuel supply. Do not use the cross-flow valve (if fitted).</li></ul></li></ol> |
|--|

<b>NOTE</b>	<i>Whisper burner will provide additional heat output.</i>
-------------	--

<b>NOTE</b>	<i>Sirius single burner has levers of main blast valve from one supply and whisper burner from other fuel supply fitted next to each other (on the same side of the burner) so that they can be operated at the same time using only one hand.</i>
-------------	--

### 3.2.3 Collision with a High Obstacle

When the obstacle is significantly higher than the balloon (chimney, tower, antenna...) and the collision is inevitable, proceed as follows:

**Priorities:** Keep the balloon in level flight. Do not climb or descend.

- |   |
|---|
| <ol style="list-style-type: none"><li>1. Maintain horizontal flight.</li><li>2. Passengers are briefed to adopt correct emergency position for collision.</li><li>3. Prevent persons from falling out of the basket during impact.</li><li>4. Decide about further steps:<ol style="list-style-type: none"><li>a. If possible and safe to do so, fly away and land behind the obstacle.</li><li>b. Otherwise stabilize the basket, inform your crew. If necessary inform ATC and call for help. Nobody leaves the basket.</li></ol></li></ol> |
|---|



### 3.2.4 Collision with a Low Obstacle - Basket Remains on the Ground

When the obstacle is of approximate balloon height or lower (tree, house, car, fence...), proceed as follows:

**Priorities:** Get the basket as low as possible, preferably on the ground.

1.		Vent to descend and lay the envelope before the obstacle.
2.		Passengers are briefed to adopt correct emergency position for collision.
3.		Shut all cylinder valves.
4.	Parachute/ Paralite (s/n up to 2199)	Prevent the balloon from lifting off again by opening the deflation system by the red line.
	Parachute/ Paralite (from s/n 2200)	Prevent the balloon from lifting off again by opening the deflation system by red-white line.
	SV, SLV, LV	Prevent the balloon from lifting off again by opening the deflation system by red line.
5.		Prevent passengers from leaving the basket until so instructed.
6.		Inform your crew and the ATC if necessary.

### 3.3 Collision with Electric Power Lines

**Priorities:** Hitting power lines with the basket wires is the most dangerous situation. Get the basket below the power lines at all costs.

Prior to the contact:	
1.	Vent to descend
2.	Passengers are briefed to adopt correct emergency position for collision with faces down, protecting sight and not touching the fuel cylinders and other metal parts.
3.	Shut all cylinder valves and vent fuel hoses.
After the contact:	
4.	Prevent the balloon from lifting off again.
5.	Call emergency line (112, 911 or local equivalent) for help and information about disconnection of the power line.
6.	Inform your crew and the ATC.
7.	Have the passengers exit the basket as the situation allows. Do not touch the basket and ground at the same time.
8.	Do not attempt to recover the balloon from the wires without an assistance of emergency units.

### 3.4 Midair Collision with Another Balloon

**Priorities:**

- Make the other balloon's pilot aware of the the risk of contact.
- Avoid direct contact of the basket with envelope.
- If basket-envelope collision is inevitable try to minimize the relative vertical speed.

### Lower balloon:

1. Stop climbing or accelerate descent.
2. In case of contact heat to keep the envelope inflated. Check the damage.
3. During fall or descent together with the upper balloon jettison fuel cylinders except one (ones) to be used for slowing down the descent in case the upper balloon detaches.
4. Instruct passengers to adopt correct position for a hard landing.
5. Prepare for hard landing (see chap. 3.6.3 Hard Landing)

### Upper balloon:

1. Stop descending or accelerate climb.
2. Prevent the lower envelope from direct contact with your basket with your hands or legs. When the other envelope is too close to your burner, avoid heating to prevent damage to other envelope.
3. In case the lower envelope is torn, try to attach it to your basket.
4. Maintain both balloons in acceptable rate of descent by intense heating.
5. Land without regard to obstacles on the ground.

## 3.5 Damage to the Envelope in Flight

**Priorities:** Keep flying the balloon to avoid a hard landing.

1. Heat to keep the envelope inflated. If the envelope mouth closes blow fire through the fabric in a convenient place. Check the damage.
2. Keep in a low altitude and land as soon as possible.
3. If the balloon descends uncontrollably, jettison gradually all heavy objects including fuel cylinders and prepare passengers for a hard landing. The cylinder used for heating is to be jettisoned last.
4. Prepare for hard landing (see 3.6.3.).

## 3.6 Non-standard Landing

### 3.6.1 Fast Landing

Landing in a relatively high surface wind

**Priorities:** Primarily avoid persons from falling out of the basket or their injury from loose objects. Make a **tangential contact to the ground** with little vertical speed.

1. Select a suitable landing field, maintain desired landing trajectory.
2. If a RV is fitted, rotate the balloon, so the balloon lands on the longer side of the basket.
3. Passengers to adopt correct emergency position for fast landing. Prepare them for being dragged on the ground after landing.
4. Descend gently.
5. Consider possibility to stop the envelope with a convenient obstacle (tree, bushes...)
6. Switch off the pilot flames on all burner units.
7. Parachute/  
Paralite (s/n  
up to 2199) Open the deflation system completely by the red line.  
Parachute/  
Paralite  
(from s/n  
2200) Open the deflation system completely by the red-white line.  
SV, SLV, LV Open the deflation system completely by the red line.
8. Prevent people from leaving basket until so instructed.

### **WARNING**

***Combination of fast horizontal motion and vertical descend is extremely dangerous and must be avoided. The touchdown is to be performed with as low a rate of descend as possible.***

### 3.6.2 Deflation System Malfunction

Should this emergency arise, the same priorities and procedures apply as the fast landing (see 3.6.1). If the envelope is fitted with a rotation vent, use it for venting. Pull on both lines to vent air. Be prepared for a prolonged drag of the basket after landing.

Report the trouble to your ground crew so they can be of help as soon possible.

### 3.6.3 Hard Landing

Landing with a high rate of descent

**Priorities:** Everyone in the basket must adopt correct emergency position to prevent injuries to legs and ankles.

1. If a RV is fitted, rotate the balloon so it lands on the longer side of the basket.
2. Passengers to adopt correct emergency position for hard landing.
3. Report a hard landing to your ground crew.
4. Shut all cylinder valves and vent fuel hoses.
5. Open the deflation system completely when close to the ground.
6. Prevent people from leaving the basket until so instructed.

### 3.6.4 Landing in Fog

Along the standard landing procedures add the following:

1. Keep a very slow descend of not more than 0.5 m/s (10 ft/min) with the use of variometer.
2. Carefully check the space below the basket and avoid obstacles.

### 3.6.5 Landing into Dry Vegetation (Grain, Grass)

Along the standard landing procedures add the following:

1. Shut all pilot flames and cool burners before touchdown.
2. Shut the main valves on the fuel tanks before deflating the balloon.

### 3.6.6 Landing in Thermal or Gusty Conditions

**Priorities:** Try to land into the center of a large open area.

Along the standard landing procedures add the following:

1. Keep level flight at the altitude where the wind direction remains stable and find a suitable landing area.
2. Make a rapid descent aiming into the center of the landing area.
3. Open the deflation system completely when close to the ground.

### 3.6.7 Landing into Tall Vegetation (Forest)

**Priorities:** Carefully choose landing area - preferably glade or path. If not possible, land gently among trees.

1. Inform your crew or the ATC.
2. Select the most suitable landing area.
3. Keep all control lines and crown line short.
4. Passengers to adopt correct emergency position for fast landing.
5. Prevent passengers from falling out of the basket during possible impact.
6. Control a gentle descent among trees.
7. Empty the fuel hoses and switch off the pilot lights before the balloon reaches the vegetation.
8. If the basket remains hung on a branch, stabilize your position, inform your crew, ATC and call for help. Nobody leaves the basket.
9. If the basket reaches ground, let the envelope fall freely and do not pull it aside with the crown line.

## 3.6.8 Landing into Build-up Area

1. Keep low and try to choose a suitable area for landing.
2. Prepare the drop line in advance for an imminent use.
3. Passengers to adopt correct emergency position for hard landing.
4. Inform your crew.
5. Release the drop line when appropriate and ask your crew or other people on the ground to drag the balloon away from dangerous objects (power lines, pylons, chimneys...)
6. Land carefully at a suitable place.
7. In a limited area let the envelope fall freely and do not pull it aside with the crown line.

## 3.6.9 Landing into Water

When unable to overfly the water due to low fuel or when unintentionally reaching open sea.

**Priorities:** Secure for non-swimmers.

1. Identify non-swimmers among passengers.
2. Report your position to ATC and your crew. Ask for help.
3. Passengers to adopt correct emergency position for hard landing.
4. Fly low, burn the maximum fuel, and avoid soaking the emergency means of ignition.
5. Land slowly on water once the fuel cylinders are empty.
6. After the envelope has fallen on the water, release it from the basket.
7. Use the basket with fuel cylinders as raft and wait for rescue.

## 3.7 Burner Failures

### 3.7.1 Ignis and Komet Burners

#### 3.7.1.1 Pilot Light Failure

1. Heat with another burner unit to initiate climb.
2. Ignite the failed pilot flame by firing another unit's main burner.
3. Check fuel quantity, hose connections, and vapor fuel pressure regulator (if used).

If no pilot light works:

4. Check vapor fuel hose and pressure regulator (double hose burners), check the fuel hose (single hose burners).
5. Try to ignite pilot light with piezo or another source of ignition.

If failure remains:

6. Ignite main burner with an emergency ignition source.
7. Keep a small flame from the main burner or use the whisper burner as a pilot light.
8. Land as soon as practicable.

#### 3.7.1.2 Main Burner Valve Blocked Open

1. Try to move the main burner lever, if still blocked then:
2. Shut off the liquid fuel valve on the respective cylinder.
3. Use another burner unit for heating or use the cylinder valve to control the burner.
4. Land as soon as practicable.

### 3.7.1.3 Main Burner Fails to Burn

1. Heat with another burner unit or whisper burner to initiate climb.
2. Check fuel quantity, hose connections and cylinder valve.
3. Land as soon as possible with the use of another burner unit.

### 3.7.1.4 No Burner Unit Working

1. Check fuel quantity, cylinder valves and hose connections for all burner units connected. If failure remains, then:
2. Reconnect to another fuel cylinder. Check REGO connector on a disconnected hose is free of a seal of another cylinder. If failure remains, then:
3. Prepare for a hard landing (see chap. 3.6.3) and instruct passengers to adopt proper positions.

## 3.7.2 Sirius Burner

### 3.7.2.1 Pilot Light Failure

1. Heat with another side of the burner (Sirius burners are equipped with two pilot lights as well as two independent fuel paths – when the pilot light controlled by the green lever fails, use the red one. For more details see the burner description in chap. 6.5.12 Sirius Burner of this FM).
2. Check fuel quantity and hose connections.
3. Try to ignite pilot light with piezo or another source of ignition.

If failure remains:

4. Ignite main burner with an emergency ignition source.
5. Keep a small flame from the main burner or use the whisper burner as a pilot light.
6. Land as soon as practicable.

### 3.7.2.2 Main Burner Valve (MBV) Blocked Open

1. Try to move the main burner lever, if still blocked then:
2. Shut off the fuel valve on the respective cylinder.
3. For heating use the whisper burner that is fed by fuel from another cylinder. That is the lever on the SAME SIDE of the burner as the blocked MBV.
4. Land as soon as practicable.

#### **NOTE**

*The control lever of whisper burner is of matching colour with the colour of fuel hose that is feeding it.*

#### **CAUTION**

*NEVER use the second main burner in case the MBV is blocked open. Part of the fuel going to the second main burner will end up in fuel tubes inside of the manifold block, where it will remain and will feed the burner after the respective main burner lever is closed causing unwanted flames from the burner until all captured propane is burnt.*

### 3.7.2.3 Main Burner Fails to Burn

1. Heat with second main burner or whisper burner to initiate climb.
2. Check fuel quantity, hose connections and cylinder valve.
3. Land as soon as possible with the use of the second main burner or whisper burner.

### 3.7.2.4 No Burner Unit Working

1. Check fuel quantity, cylinder valves and hose connections for all burner units connected. If failure remains, then:
2. Reconnect to another fuel cylinder. Check REGO connector on a disconnected hose is free of a seal of another cylinder. If failure remains, then:
3. Prepare for a hard landing (see chap. 3.6.3) and instruct passengers to adopt proper positions.

## 3.8 Fire

<b>CAUTION</b>	<p><i>The fire extinguisher must always be used in the vertical position. Be aware that it will only last for a few seconds.</i></p> <p><i>If a dry powder extinguishing is used to fight the fire then all traces of the powder must be removed as soon as possible after landing because the powder, when exposed to the air, is extremely corrosive.</i></p>
----------------	---

### 3.8.1 Fire in the Air

1. Shut off liquid fuel valves on all cylinders. In case the fire occurs on the cylinder in use, close the shut off valve with the use of the fire blanket.
2. Open main burner valves to vent fuel with the use of fire resistant cloth.
3. Use fire extinguisher to extinguish the fire.
4. Land as soon as possible using the undamaged burner unit/fuel system.
5. If no burner can be used/works, prepare for hard landing (see chap. 3.6.3) and instruct passengers to adopt proper positions.

### 3.8.2 Fire on the Ground

- |    |  |
|----|--|
| 1. | Shut off liquid fuel valves on all cylinders. In case the fire occurs on the cylinder in use, close shut off valve with the use of fire blanket. |
| 2. | Open main burner valves to vent fuel with the use of fire resistant cloth.   |
| 3. | Use fire extinguisher to extinguish the fire.  |
| 4. | Parachute/ Paralite (s/n up to 2199) Open the deflation system completely by the red line.   |
|    | Parachute/Paralite (from s/n 2200) Open the deflation system completely by the red-white line.   |
|    | SV, SLV, LV Open the deflation system completely by the red line.  |

<b>WARNING</b>	<p><i>If it is not possible to extinguish the fire immediately then evacuate everyone to a safe distance as soon as possible because the cylinders may explode.</i></p>
----------------	---

### 3.9 Gas Leak

1. Shut off all the pilot lights.
2. Shut off fuel to the respective fuel hose.
3. Open the main burner valve to empty the fuel hose.
4. When propane is no longer detectable relight the not affected burner unit(s)/fuel system.
5. Land as soon as possible.

### 3.10 Accidental Operation of SLV, SV, SLV (3 control lines), LV in Flight

1. If the red line was pulled unintentionally in flight, close the DS immediately :
  - for SLV or SV by RED-WHITE line,
  - for SLV (3 control lines) or LV by WHITE line.

**WARNING** *The Vent panel will not automatically re-close on release of the red line.*

### 3.11 Night Flying

#### Entanglement of Light

If the light is entangled firmly in a tree or another obstacle on the ground try to free it by heating the balloon or cut the light cable with a knife.

#### Position Light Malfunction

If the red flashing light is not working, take the following steps:

1. Check the electrical connections. If failure remains then:
2. Change the fuse in the male connector. Unscrew the connector top, remove the fuse and replace it with a new one. Spare fuses are in the position light storage bag. If failure remains, then:
3. Use irregular short bursts of whisper burner to illuminate the envelope. When in controlled airspace inform the ATC about the failure.

INTENTIONALLY LEFT BLANK



## SECTION 4 - NORMAL PROCEDURES

### 4.1 Introduction

#### Use of Written Checklists

This section provides information for checklists and procedures for normal operation. Handy checklists on flip cards are a practical solution for balloon pilots. Pilots should always use written checklists. Balloon pilots need checklists because they are frequently distracted by passengers, by-standers and other balloon traffic at events. Balloon pilots are encouraged to create their own checklists. These checklists can be customized to the needs of the pilot and the configuration of the balloon model. As a minimum, written checklists should be used for the following procedures and manoeuvre: Layout and Assembly, Launch, Ascent, Level Flight, Descent, Landing and Recovery. Other checklists can be created for: Preflight Inspection, Inflation, Pre-Launch, Launch over Obstacle, High Wind Landing and emergency procedures.

### 4.2 Flight Planning

The following pre-flight preparation is to be completed before leaving for the launch field:

#### 4.2.1 Meteorology

Obtain a current aviation weather briefing for the expected flight time and location. Make sure the meteorological conditions are expected to remain within limits for the duration of the flight. High winds, thermals, gusts, fronts and thunderstorms are conditions not favourable for flight. Pay attention to local meteorological conditions. Ask local pilots if you are not familiar with local flying areas and special weather conditions for balloons. Sunrise is the only time to fly in some areas.

Obtain a forecast of the winds aloft to plan the launch location and desired flight path. Release a small helium balloon to determine the latest wind situation.

Consider the effect of ambient temperature on the fuel pressure and performance of the balloon.

Obtain an updated weather forecast. The final weather evaluation is to be made just prior to the launch to ensure that existing conditions are still suitable for the flight.

Make sure that the visibility stays above 1 NM (or minimum limit required by the local authorities) during the entire flight.

#### 4.2.2 Airspace

Use an official up-to-date aviation chart to verify the airspace limitations, minimum visibility and required equipment (radio, transponder, night light).

#### 4.2.3 Paperwork

Verify all necessary documents required by the appropriate national authorities are present and valid.

#### 4.2.4 Site Planning

With knowledge of the weather situation and amount of fuel select a launch site with regards to its size and landowner's permission, expected flight trajectory and obstacles. Consider suitable landing area with several backup landing sites.

**WARNING** *Ensure that there are no power lines in the area selected for take-off.*

## 4.2.5 Balloon Weight Limits

Verify the balloon will remain within its weight limitations - MTOW, Maximum lifting capacity, MLW - during the entire flight. Consult chapter 5 of this Manual for detailed instructions.

## 4.2.6 Check of Completeness and Fuel

During or after loading of equipment verify completeness of equipment. Verify the amount of fuel, its pressure and any need for pressurization of fuel cylinders.

<b>NOTE</b>	<i>Fuel consumption will vary greatly with different flight profiles and ambient temperature. A fuel reserve for 30 minutes of flight is recommended. When uncertain about the fuel consumption of a balloon, ask the manufacturer for advice.</i>
-------------	--

<b>CAUTION</b>	<i>Pay particular attention when intending to fly an envelope of bigger size with only a minimum allowed fuel on board. This will allow for only a short flight.</i>
----------------	--

<b>CAUTION</b>	<i>The fuel consumption is significantly increased by:</i> <ul style="list-style-type: none"><li>• envelope temperature above 115°C (239°F)</li><li>• abrupt maneuvering</li><li>• frequent in-flight venting</li><li>• use of RV</li></ul>
----------------	---

## 4.2.7 Flight Planning and Weather for Night Flying

Make a careful flight plan including weather, fuel consumption and maximum operation time of the position lights. Ensure adequate quantity of fuel is carried to permit a reserve for at least 30 minutes of flight after sunrise.

Before departure to the takeoff site:

Make sure the battery is fully charged.

Check that the position lights work correctly.

<b>CAUTION</b>	<i>At night the fuel consumption is substantially higher due to the absence of solar heating.</i>
----------------	---

<b>WARNING</b>	<i>Landing at night is dangerous and needs to be avoided.</i>
----------------	---

## 4.3 Preparation, Assembling the Balloon and TAKE-OFF

### 4.3.1 Launch Site

Select a flat area large enough to lay the balloon out safely with easy access for the retrieve vehicle without obstruction in the downwind direction and without objects that could damage the envelope. The area for spreading the envelope should ideally be a smooth grass surface without rocks, sticks, tough shrubs and other objects likely to damage the envelope.

Manipulating the balloon envelope on abrasive surfaces (concrete, tarmac, paving, sand...) should also be minimized as it causes excessive degradation of envelope fabric. It is recommended that the envelope be unpacked into a long "noodle" and let it be blown to the sides by the inflation fan which helps to minimize dragging the fabric on the abrasive surface.

Pay attention to the landowner's rights and obtain permission to use the land if necessary.

The selected site must allow for a safe departure clear of obstacles with the actual load and particularly wind direction and speed. The stronger the wind the farther the balloon must be placed from obstacles.

<b>WARNING</b>	<i>Make sure there are no power lines in the departure path.</i>
----------------	--

<b>NOTE</b>	<i>If the wind speed is strong (more than 4 m/s [8 kts]), it is recommended that you use a launch site that gives protection from the wind.</i>
-------------	---

### 4.3.2 Decision on the Flight

<b>Weather</b>	Weather conditions within limits, no thermals, no thunderstorm or any other weather phenomena possibly dangerous in the vicinity of the intended flight
<b>Launch site</b>	No downwind obstacles
<b>Weight</b>	The balloon is within weight limits and capable of staying that way during the entire flight
<b>Fuel</b>	At least the minimum quantity of fuel is present and is enough to complete the intended flight

#### WARNING

**NO FLIGHT IS PERMITTED** if there is a chance that the surface wind speed during the flight will exceed limitations for safe landing (see 2.2). Never attempt to fly when there is thunderstorm activity in the area, ahead of approaching frontal systems, or near severe weather of any kind (turbulence, thermals, or wave currents etc).

### 4.3.3 Crew Briefing

The briefing for the ground crew is done by the pilot preferably before unpacking the balloon and no later than before starting the inflation fan. A map should be provided the crew with the launch site identified and the course laid out showing direction and length of flight.

#### WARNING

*Instruct every crew member, especially the crown crew, to immediately release all ropes or other equipment if there is a risk of being lifted off the ground!*

#### Crown Crew Briefing

- Clothes:** Strong gloves, suitable shoes
- Dos:** Hold the end of the crown rope, stabilize the envelope by pulling it during inflation. Prevent it from rolling from side to side and rising before it is buoyant.  
During hot inflation pull the rope back, slow down the upright motion of the envelope and move slowly towards the basket.  
As the envelope comes upright, pull hard to prevent it from swinging over the basket.  
Upon pilot's signal bring the crown rope and clip it to the basket. Then help to hold the basket.  
Inform pilot if anything unusual was observed during the inflation.
- Don'ts:** Don't wrap the rope around the waist, arm or any object.  
Don't accept help from other people.

#### NOTE

*Smaller envelopes (below 10 000 m<sup>3</sup> / 353 100 cu.ft.) are fitted with one crown line. Bigger envelopes have two crown lines.*

#### WARNING

*The crown crew person should never wrap the crown line around any part of the body. Nor should the loop in the end be looped around the wrist.*

#### Mouth Crew Briefing

- Equipment:** Strong gloves, clothes made of natural fibre or heat resistant fabric protecting arms and legs from burner heat.
- Dos:** Hold the envelope mouth open with the flying cables taut and clear of the burner flame.  
Hold the basket once the envelope is upright  
One person to control the inflation fan, direct the airflow into the mouth of the envelope parallel to the burner flame, turn off the fan on pilot's signal and move it clear of the balloon.  
One person to keep bystanders away from the balloon and quick release rope if necessary.
- Don'ts:** Don't put legs between flying cables.  
Don't allow bystanders to help or walk over or under the quick release rope.

#### WARNING

*Mouth crew should be briefed to never allow a foot or leg to get inside a mouth cable as this can result in injury.*

#### WARNING

*Quick release rope can fling sharply when released. Keep bystanders away from the area between the basket and tether point at all times to prevent injury.*

**WARNING**

*The crew operating the fan should not wear any loose clothing, scarf, neck lanyard, long loose or braided hair as these items can pass through the fan guard.*

**WARNING**

*Always inspect the fan before use to insure safe function and all fasteners and cage are secure.*

#### 4.3.4 Passengers briefing

A correct briefing to the passengers is essential for the safety of the flight. Passengers receive this briefing from the pilot during any stage of preparation prior to take off. Correct landing position (see Chap 4.5.3) and emergency positions (see Chap 3.1.1) are to be physically demonstrated. Pilot ensures the briefing was well received and understood.

**Do's:**

Follow the pilot's instruction at all times.

Stay clear of the inflation fan.

Before landing:

Stow all loose object such as cameras.

Adopt the landing position.

On landing:

Hold on to rope handles to maintain this position.

Stay low in the basket and bend knees. Heads always below the upper rim of the basket.

Keep feet flat on the basket floor.

Keep hands and arms within the basket.

Watch the progress of the landing and brace for the touch-down.

Be aware that the basket on landing may tip over and drag along the ground.

Remain in the basket until instructed to leave by the pilot.

**Don'ts:**

Hold onto the fuel hoses or interfere with the control lines, burner controls or fuel cylinder valves.

Interfere with any of the balloon controls.

Smoke in the balloon or within 30 m (100 ft) of the basket.

Throw anything from the basket.

Touch the door and partitions or securing carabiners.

On landing:

Wrap their arms around the burner support rods.

Leave the basket before instructed to do so by the pilot.

**WARNING**

*It is dangerous to rely on a passenger to assist with the deflation line, fuel system, or as navigator or obstacle spotter during the flight or during the landing. These are pilot responsibilities which should not be delegated to persons without balloon piloting experience and without authority to act on their own judgment.*

**WARNING**

*Do not allow any part of the body, including hands, to wrap around the upright poles on landings.*

**WARNING**

*There is a risk of personal injury if an inexperienced person (e.g. passenger) is asked to help with the balloon handling before takeoff or after landing. If you do so always provide to such person detailed instruction which includes means of minimizing of the associated risks.*

### 4.3.5 Unpacking and Assembling of the Balloon

1. Unload the entire balloon, inflation fan and quick release from the vehicle or trailer. Orient the basket with the red-marked wire to the right forward position. Place the vehicle on the upwind of the basket, 3 - 5 m (10 - 15 ft) away and brake it well. Place the envelope in its bag on the downwind side of the basket far enough apart so that the basket can be laid down later.

**NOTE** For details how to assemble the collapsible baskets K10C and K13C and the attachment of the fuel cylinders refer to Appendix 8.

2. Inspect the general condition of the fuel cylinders, check that the fuel cylinders are full (this is done by opening „maximum fuel valve“ for short period of time - if liquid fuel flows out, the cylinder is full; close the valve immediately), then place them into the basket.

If Master fuel cylinders are used place them preferably to the downwind side of the basket.

Attach fuel cylinders to the basket walls with the straps passing through lugs in the basket wall and tighten well. The position of the upper strap is to be selected appropriate to the cylinder height as shown in the picture. The strap must encircle the cylinder body in its upper part, not its middle part or the fitting protection cover.

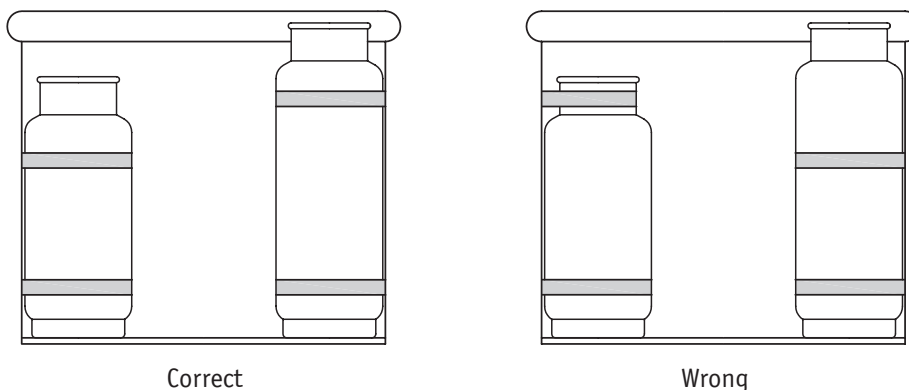

**WARNING** Use only approved cylinder straps.  
Leather fuel straps may not be used at all.  
Make sure all cylinders are correctly attached! Loose cylinders are extremely dangerous.  
No part of any fuel cylinder may overlap the upper edge of the basket.

3. Inspect the condition of burner support rods and put them into the sockets in the top frame of the basket.
4. Inspect the general condition of the burner and burner frame, then place the burner on top of the rods with the red-marked hose on the right side.
5. Inspect visible parts of the basket suspension wires and attach them to the burner frame using the carabiners. Screw in the gates on the carabiners and turn back a half-turn. The correct attachment is shown on the illustration. If a variable height burner frame is used, keep it in the lowest position until the balloon is upright. If Ignis Gyro burner frame is used, unlock the burner from the upright position by pulling the central pin before laying the basket on the side.

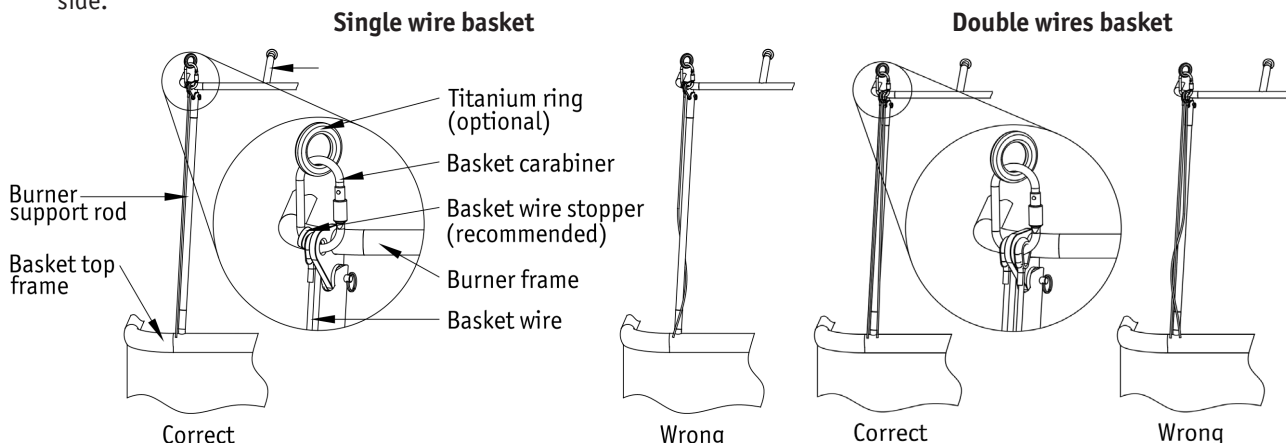

\*if titanium rings are used, they have to be fitted at all attachment points

- Organize the fuel hoses. Lead them along the burner support rods along the side of the rod that is facing the centre of the basket while selecting the minimum distance along the basket wall possible. The walls with step holes shall be avoided (except K10C and K13C - refer to Appendix 8). Zip the padded covers over the basket wires, the burner support rods and the fuel hoses. Ensure that the hoses have sufficient slack at the top to allow the burner to gimbal.

**WARNING** When installing the padded burner support covers ensure that the hoses are located inside the basket.

**CAUTION** Fuel hoses may never be bent sharply, the smallest bend radius allowed is 90 mm (3 1/2"). A template is provided in Appendix 5.

- Connect the fuel hoses to the cylinders that are to be used last and make a functional check of the burner. Verify the pilot burner, main burner, whisper burner and gimbal is free to move in both directions. Next, verify that the fuel is correctly supplied to the burner from all fuel cylinders, that there is no leak in the system and that the fuel pressure is within limits. When a reconnection of fuel hoses is necessary, shut off the liquid valves on the cylinder and burn the remainder of the fuel from the hose by opening the main burner. Then switch off all pilot flames. The fuel cylinders intended to be used first should be checked as the last and remain connected and not vented.

**WARNING** Make sure that there is no flame at the burner when reconnecting the fuel hoses!

**CAUTION** Never vent unburned fuel from the hoses when reconnecting them!

**CAUTION** The locking ring on the Tema fitting must be in the locked position to prevent inadvertent disconnection.

**NOTE** The use of fuel T-manifolds is advisable because it eliminates reconnections of the fuel hoses.

- Lay the basket on its side with the burners pointing downwind with the red covered basket wires on the lower right corner. If Ignis Gyro burner frame is used, lock the burner in the upright position by pushing the central pin.
- Open the envelope bag, unfold the envelope mouth and attach the flying cable carabiners to the basket carabiners or to the titanium rings, if they are used. The envelope should be attached so that the envelope identification plate is on the upper side of the envelope and central to the basket. When a 4-point burner frame is used the envelope flying cables are to be distributed evenly among the attachment points. When an 8-points burner frame is used the envelope flying wires are to be distributed as shown on the illustration below.

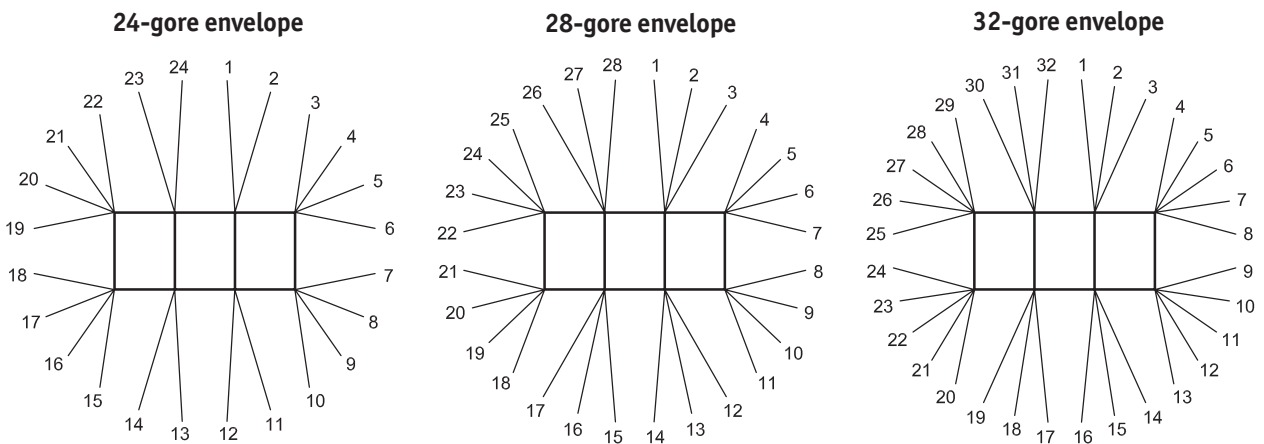

Flying Wires Attachment - Pilot's View

**NOTE** The arrangement of flying wires can differ in the case the bottom end from another manufacturer is used. If in doubt, contact KB for advice.

10. The carabiner on the red flying cables attaches to the carabiner on the red basket wires. Check that the flying cables are not twisted and then close the screw gates on the carabiners fully and release by a half-turn.
11. Pull the envelope from its bag and spread it out either directly onto the ground or onto a pre-positioned ground sheet. Fully deploy the crown line downwind. If two crown lines are used, deploy them into a wide V-shape.  
On a smooth surface spread the envelope by pulling on load tapes only. On a hard surface use the fan to spread the envelope. Attach the scoop to the envelope carabiners. Place DS and RV control lines into the basket. The red-white line (vent line) of the SV and SLV and red-white (vent line) and white line (reset line) of the LV are to be preferably placed in their bags in the basket. When using the electronic thermometer attach its sensor correctly onto the envelope. In the envelope, pay attention not to confuse the temperature sensor wire and the antenna.
12. Attach a quick release to the upwind envelope carabiners or to the titanium rings, if they are used, and then secure the other end of the restraint rope to a secure anchor point (details in chap. 4.3.6).
13. Position the fan on the side of the basket. Make sure that someone looks after the fan whenever it is turned on.

**WARNING**

*Failure to screw down the locking collar of a carabiner may result in distortion of the carabiner, making connection and disconnection of the carabiner difficult or impossible in the future. This could cause possible failure under extreme flight loading, which could result in injury or death.*

**Additional information for assembling the balloon:**

Always lay the basket with the door closed and on the up side.

The pilot must also decide on arrangement of removable partitions, basket occupancy and distribution of passengers. All items must be properly installed and secured before the basket is laid down for inflation.

When the pilot chooses to use the seat, it should be installed into the basket prior to cold inflation.

Seat installation:

1. Insert the pins in the underside of the trestle into the grooves in metal plates on the basket floor and slide the seat sideways to fasten all pins.
2. Screw in the central bolt and tighten by hand.

**NOTE**

*The correct orientation of seats must be taken into account. All seats must be installed so that all seating passengers face the same direction with their backs to the direction of flight before landing, if possible.*

**During pre-flight preparation:**

The weight and floor area occupancy of the seat is to be taken into account. The actual weight of the complete set is engraved on the trestle.

Floor area occupied by the seat: 0.27 m<sup>2</sup> (2.9 sq. ft)

**4.3.6 Quick Release****WARNING**

*The quick release is an essential safety item that shall be used for all inflations, even during calm conditions. Ensure that the correct type of quick release is used for your basket/burner frame. Using the wrong type quick release, or not using it at all, can cause damage/injury.*

**Standard Quick Release**

Attach the carabiners at both ends of webbing to the envelope carabiners or to the titanium rings, if they are used. Make a loop on the restrain line and place it into the jaw of the quick release and lock it with a securing pin. The other end of the restrain line is to be fixed to a solid ground point or to the front of a heavy vehicle.

**Y-type Quick Release**

Place the quick release on the attachment lug closest to the pilot's compartment. Fix one end of the rope to another lug with a carabiner, next pass the rope through the ring at the end of the restrain line, then place the rope loop into the jaw of the quick release and lock it with a securing pin. The other end of the restrain line is to be fixed to a solid ground point or to the front of a heavy vehicle.

On some older K25P burner frames that are not fitted with attachment lugs fix the rope end to the envelope carabiners or to the titanium rings, if they are used.

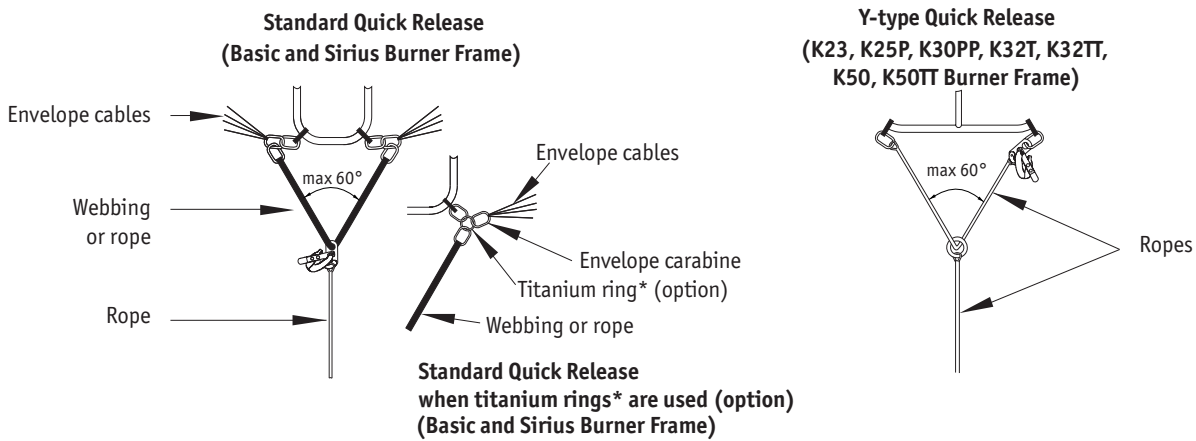

\*if titanium rings are used, they have to be fitted at all attachment points

## W-type Quick Release

The W-type quick release uses the quick release webbing or ropes attached to the central attachment lugs together with a rope of a correct length attached to the outer attachment lugs by loops. This rope passes through the restrain line and attaches to the quick release jaw. Lock the quick release with the securing pin. The other end of the restrain-line is to be fixed to a solid ground point or to the front of a heavy vehicle.

There is a difference between rope length of W-type Quick Release for attaching to burner frame (both ropes with attachment carabiners are red) and for attaching to basket lugs (both ropes with attachment carabiners are green).

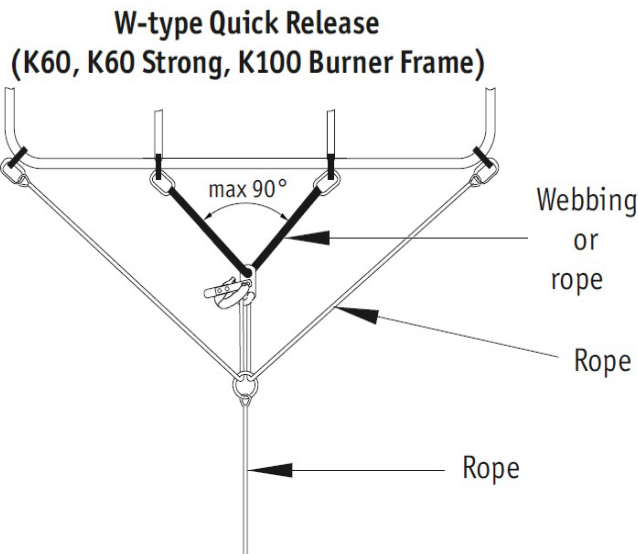

For W-type Quick Release use set with red ropes when attaching to the burner frame and set with green ropes when attaching to the basket lugs.



### X-type Quick Release

This system uses two ropes: The inner rope with a ring attaches to the inner attachment lugs by loops. The outer rope has a loop on one end attached to the outer attachment lug, then passes twice through the restrain line ring and once through the inner rope ring as shown in the picture. The other end of the outer rope attaches to the quick release jaw fixed to another outer attachment lug. The other end of the restrain line is to be fixed to a solid ground point or to the front of a heavy vehicle.

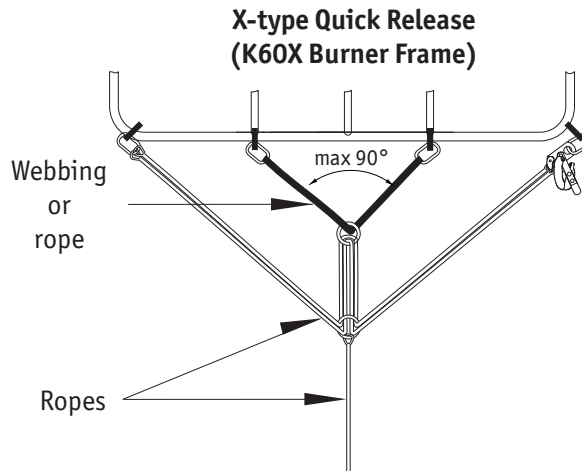

**WARNING** For approved combination of KB envelopes and bottom-end from different manufacturer, make sure to use approved quick release for your specific equipment.

**WARNING** Never attach the restrain line to the trailer.

**WARNING** No person is allowed in the area between the basket and the front of a vehicle due to high risk of serious injury.

**WARNING** The most common angle between webbing arms is between 60 and 90 degrees, as per quick release type, for preventing overstressing of the burner frame.  
For 60 degrees the lengths of the webbing arms are to be the same as the distance between their attachment points - envelope carabiners or attachment lugs.  
For verifying the 90 degrees the pilot can use any suitable rectangular object e.g. map folder, flight log etc.

**WARNING** The fixed point for attaching the quick release rope must be able to carry the following load:  
MTOW of the respective balloon + 800 kg (1760 lb)  
This load is established for the maximum surface wind speed allowed for take-off. In slower wind the load capacity of the fixed point can be reduced in direct proportion to the maximum allowed and actual surface windspeed.

**WARNING** The quick release shall be operated by the pilot only.

### Basket tethering lugs

For takeoff the quick release can be attached to the basket lugs instead of envelope carabiner or burner frame lugs. The quick release type remains the same as it would be without basket lugs; according to the burner frame.

## 4.3.7 Cold Inflation and Pre-flight Check

<b>CAUTION</b>	<i>In windspeeds 5.0 m/s (10 kts) and higher the controllability of the balloon is difficult. It is recommended to use two inflation fans and sufficient number of crew members for envelopes of 7000 m<sup>3</sup> and bigger.</i>
----------------	---

1. With the crew in position start the inflation fan which is placed in the braked position on the left side of the basket. The air flow should be aimed to the left of the mouth centre so that the burner flame is not disrupted. The fan remains turned on during the entire inflation. The crew turns it off on the pilot's instruction.
2. One or two crew members remain at the crown and close the DS by connecting the proper velcro tabs identified by numbers and colour. Start at the top (first and last number) and continue gradually downwards.
3. The pilot makes an inspection of the basket and both the internal and external parts of the envelope:

<b>Envelope</b>	Fabric damage within permitted limits
<b>Crown ring</b>	Crown ring, load tapes and load tapes loops undamaged and the crown line properly attached and undamaged
<b>Envelope mouth</b>	Load tapes and load tapes loops are undamaged, and the fabric damage within permitted limits
<b>Steel flying wires</b>	No broken strands, rust, kinks, heat damage, entanglement
<b>Kevlar flying wires</b>	Check all the wires along their whole length. The wire must be flexible and free of mechanical damage. The yellow core must not be exposed. Damaged wires must be replaced. Instructions are given in Appendix 3 of this Manual.
<b>Quick link carabiner (if fitted)</b>	Undamaged and secured
<b>Joints of load tapes and flying wires</b>	All load tape loops, carabiners and protecting sleeves are free of damage
<b>DS and RV lines</b>	Check them along their entire length for damage and free of knots and twists. Ensure that the loose ends of the control lines are not entangled/crossed. The ends of all control lines must be attached to the envelope carabiners or the basket and be located within the pilot's reach.
<b>Paralite bungee (if fitted)</b>	Undamaged
<b>Pulleys</b>	Undamaged and rotating freely
<b>Temperature streamer</b>	Present and the flag not twisted
<b>Tempilabel</b>	No signs of overheating
<b>DS panel</b>	Correctly placed
<b>Deflation openings (if fitted)</b>	All closed
<b>Quick release and restrain line</b>	Quick release correctly attached to the envelope carabiners or burner frame lugs if fitted. Restraint line attached to an anchor point
<b>Carabiners</b>	All present, undamaged, correctly arranged and secured
<b>Titanium rings (if fitted)</b>	Attached to all basket carabiners, undamaged and secured

<b>WARNING</b>	<i>Heat damage, which may cause a significant loss of strength of a steel wire, is indicated by charring, blackening or bluing, or by a presence of a permanent deformation or kink after being bent.</i>
----------------	---

<b>CAUTION</b>	<i>Keep loose items away from the inflation fan to prevent entanglement with the propeller.</i>
----------------	---

<b>CAUTION</b>	<i>The temperature sensor must be placed in the same distance from the envelope skin as the melting streamer.</i>
----------------	---

<b>NOTE</b>	<i>It is possible to have flying wires attached directly to the load tape loops or via quick link carabiners. Combination of both methods on one envelope is allowed.</i>
-------------	---

<b>Basket</b>	Correctly assembled. Inspect condition of the basket floor and basket walls.
<b>Basket wires</b>	The basket wires are free of damage and not exposed below the leather protecting covers at the bottom, and correctly connected to carabiners (refer to chap. 4.3.5.)
<b>Equipment, Instruments and Accessories</b>	Altimeter, variometer and envelope temperature indicator switched on and set. Two sources of ignition, fire extinguisher, drop line and Nomex heat-resistant cloth all present and correctly stowed.
<b>Burner</b>	Functional check completed. No damage to the burner units, gimbal block and burner frame. Check all the burner valves are turned off.
<b>Sirius Burner</b>	Functional check completed – main burner, both pilot lights and both whisper burners are fully functional.
<b>Adjustable height burner frame(if fitted)</b>	In the lowest position.
<b>Fuel hoses</b>	All hoses without damage, without sharp bends (minimum radius observed, see App. 5), correctly attached to the cylinders that will be used first. For collapsible baskets K10C and K13C lead the hoses on the short sides through the tunnels on the sidewalls.
<b>Ignis gyro (if fitted)</b>	Check the tightness of the top bolt.
<b>Fuel system</b>	No gas leaks on entire fuel system.
<b>Cylinders</b>	Correctly strapped into the basket. The hoses attached and the connectors properly tightened.
<b>Cylinder harness (K10C and K13C baskets)</b>	Each of 4 cylinder harnesses tightened. All 3 buckles tightened when fuel cylinder is placed in the harness for more details refer to Appendix 8.
<b>Fuel</b>	Sufficient fuel level for the intended flight (for minimum see chap 2.3)
<b>Basket door (if fitted)</b>	Check correct function
<b>Seat (if fitted)</b>	Check its attachment to the basket floor
<b>Removable partition (if fitted)</b>	Check its attachment to the basket floor and walls

**WARNING**

*All cylinders and heavy objects are to be secured in the basket by cylinder straps so that they will not move around and cause injury to the basket occupants during the landing. Attaching objects (except fabric banners, radio aerials and the envelope bag) on the outside of the basket is prohibited.*

**WARNING**

*Failure to check the tightness of the hand-tighten fittings in the fuel system may result in insufficient burner heat output for controlled flight.*

**WARNING**

*The fuel hose leading along the short side of the K10C and K13C basket must go through the tunnel on the sidewall. The fuel hoses must not be stepped on as this can cause their damage resulting in serious injury/death.*

## 4.3.8 Hot Inflation

<b>Crew</b>	Briefed, in place and ready for the hot inflation.
<b>Restraint</b>	Balloon securely restrained.
<b>Inflation fan</b>	Running and the envelope cold inflated, power setting as appropriate to the envelope size.
<b>Heating</b>	Short bursts of heat from the burner into the envelope.
<b>As the envelope starts to lift</b>	Step into the basket and heat intensively to keep the envelope moving up steadily, lift the basket together with the envelope into the vertical position. Switch off the fan and remove it to a safe distance. Crown crew moves in towards the basket, but stops a distance away to prevent the envelope leaning back over the basket.
<b>Restraint line</b>	Move the basket downwind so that the restraint line is tight. With the basket upright the crew applies their weight on the basket to prevent it lifting.
<b>Envelope bag</b>	If the envelope bag is to be carried, attach it to an outer basket loop.
<b>Getting ready for take-off</b>	Crown crew brings the crown line end and attaches it to the burner support rod or the burner frame or carabiners.

<b>CAUTION</b>	<i>Do not attach the envelope bag handle rope onto fuel fittings on the tank or manifold or instruments or instrument bracket.</i>
----------------	--

<b>CAUTION</b>	<i>Do not manipulate with the inflation fan when the engine is switched ON to prevent dangerous contact between the propeller and the protective cover.</i>
----------------	---

<b>CAUTION</b>	<i>Extreme care should be exercised to prevent damage to envelope fabric when burning. Heat damage can result when the flame is close to the fabric causing melting, embrittlement, or loss of strength.</i>
----------------	--

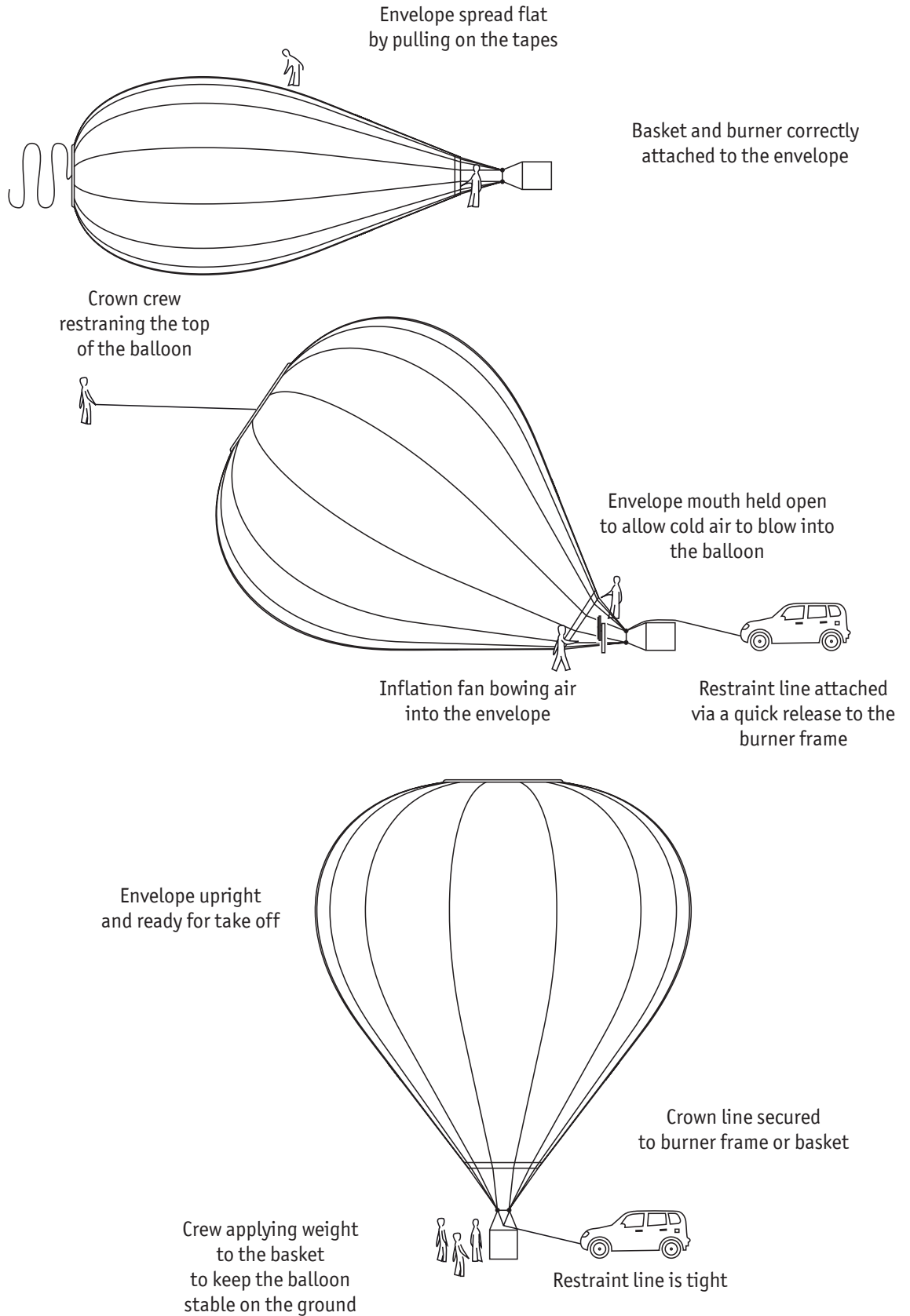

**Inflating a Balloon**

## 4.3.9 Pre-Take-off check

<b>Heating</b>		Heat as appropriate to keep the envelope upright and pressurized.
<b>Venting</b>	Parachute/ Paralite (s/n up to 2199)	Release velcro tabs by pulling the <i>red line</i> . Check function of the venting and correct seal after releasing the line.
	Parachute/ Paralite (from s/n 2200)	Release velcro tabs by pulling the <i>red-white line</i> . Check function of the venting and correct seal after releasing the line.
	SV, SLV and LV	Release velcro tabs by pulling the <i>red-white line</i> . Check function of the venting and correct seal after releasing the line.
<b>Function check</b>	SV, SLV	Check operation of the deflation mode - open the SV / SLV partially by pulling on the <i>red line</i> , close by the <i>red-white line</i> .
	LV, SLV (3 control lines)	Check operation of the deflation mode - open the vent partially by pulling on the <i>red line</i> , close either by the <i>red-white line</i> (reset by the <i>white line</i> if necessary) or close by <i>white line</i> .
	Rip panel	Check the correct seal. The locks secured.
<b>DS control lines</b>		Free to move, not entangled, attached to the envelope carabiner of in the basket, within pilot's reach.
<b>RV</b>		Check function.
<b>Crown line</b>		Fixed in pilot's vicinity.
<b>Envelope</b>		No unacceptable damage.
<b>Carabiners</b>		Closed and locked.
<b>Burners</b>		All burners working correctly.
<b>Pilot flames</b>		Correct function of the pilot burner - flame only around the upper part, not blowing from the lower holes.
<b>Fuel system</b>		Hoses connected, cylinder turned on as required. No leaks.
<b>Radios and Instruments</b>		Altimeter correctly set, instruments turned on, thermometer working. Radio checked.
<b>Ignition sources</b>		Within easy reach.
<b>Positioning</b>		Ground crew move the basket downwind to the full length of the quick release rope, then hold the basket on the ground.
<b>Map</b>		Map(s) showing the intended flight path present.

**WARNING** Do not attach any objects on to the fuel fittings.

**WARNING** NO FLIGHT IS PERMITTED if there is a leak in the fuel system or a pilot flame malfunction!

**CAUTION** Force required to manipulate the deflation system lines may increase during the balloon operation. Always check that the pilot is able to operate the deflation system.

## 4.3.10 Passenger Boarding

Instruct passengers to enter the basket with no partitions on its upwind side, and when you use the partitioned baskets place them into the compartments so that the weight is distributed evenly. The pilot keeps his or her position close to control lines and most of the fuel tanks.

**NOTE** Although it is possible it is not recommended that a passenger be placed into the pilot compartment in partitioned baskets.

**WARNING** Only load passengers when the restrain line is tight.

**WARNING** While boarding K10C and K13C collapsible baskets, the fuel hoses on the short side of the basket must lead through the tunnels. The hoses must not be stepped on as this can cause their serious damage and possible fuel leak.

During windy conditions it is possible to board the passengers before inflation (used especially when the surface wind speed reaches the level when balloon may be swinging while upright, causing boarding of passengers inconvenient or possibly risky).

<b>NOTE</b>	<i>This practice is applicable for all models except for open baskets.</i>
-------------	--

When you decide to use this procedure, in addition to standard procedures, follow the steps below:

1. Instruct your ground crew that the passengers will be boarding prior to inflation. Instruct especially the mouth crew and fan crew to monitor the passengers and instruct them, if needed, to remain in the basket.
2. Instruct passengers as per standard passenger briefing, with addition of the following instructions:
  - Passengers from the upper partitions must enter the basket first.
  - Once in the basket, passengers must remain in their place, with bent legs, back leaning on the bottom partition or basket wall, fully covered with the sides of the basket.
  - Passengers are prohibited to tamper with control lines, flying wires attachment carabiners, fuel hoses, fuel cylinders or burner.
3. Assemble the balloon following standard procedures.
4. Board the passengers:
  - Passengers from the upper partitions must enter the basket first
  - Once in the basket, passengers must remain in their place, with bent legs, back leaning on the bottom partition or basket wall, fully covered with the sides of the basket.
  - Passengers are prohibited to leave the basket.
  - Passengers are prohibited to tamper with control lines, flying wires attachment carabiners, fuel hoses, fuel cylinders or burner.
5. Place the inflation fans along the basket sides (all passengers should be protected by the basket walls from possible debris coming from propeller).
6. Continue with inflation as per 4.3.7 and 4.3.8.

<b>WARNING</b>	<i>If any passenger disobey the instructions and start leaving the basket, stop the inflation immediately!</i>
----------------	--

<b>WARNING</b>	<i>Pay attention to any loose clothing or other items that may get entangled to the flying wires, control lines or inflation fan. Such situations are extremely dangerous and may lead to fatal injuries.</i>
----------------	---

<b>WARNING</b>	<i>It is prohibited to board or disembark passengers when inflation fan is running.</i>
----------------	---

#### 4.3.11 Take-off

<b>Basket door (if fitted)</b>	Closed and secured on both sides.
<b>Balance</b>	Balloon in equilibrium
<b>Basket area</b>	Clear of equipment and people
<b>Basket check</b>	No person or object attached to the outside of the basket
<b>Passengers</b>	In the landing position for the fast landing
<b>Passengers in the seat (if fitted)</b>	Sitting in the seat with harness correctly worn and adjusted.
<b>Airspace</b>	Area around and above the balloon clear of other traffic, safe for climbing
<b>Ground crew</b>	Release the basket gradually
<b>Heat</b>	Heat to lift off
<b>Quick release</b>	Pin removed and then release.
<b>Obstacles</b>	Clear the obstacles
<b>Time record</b>	Note take-off time.
<b>Quick release</b>	Remove the quick release. Stow the quick release line inside the basket (Y-Type and X-Type only).
<b>Weather</b>	No weather dangerous to the flight
<b>Position lights (if fitted)</b>	Deploy and switch on.

<b>WARNING</b>	<i>Never use crew pressing down on the basket to build up excess lift before leaving the ground.</i>
----------------	--

<b>CAUTION</b>	<i>During taking-off remember to climb at a rate appropriate to the prevailing wind speed and direction to ensure safe over-flight of downwind obstructions. Pilot is to face forward.</i>
----------------	--

<b>CAUTION</b>	<i>In windy conditions be aware that the balloon may, even in light wind, on lift off, suffer from 'false lift' that will be lost as the balloon accelerates to the prevailing wind speed. As 'false lift' decreases so it will have to be replaced by extra burning. 'False lift' is the lift generated by the wind blowing over the top of the balloon while it is stationary.</i>
----------------	--

<b>NOTE</b>	<p><i>If, in windy conditions, you chose to inflate the balloon in the shelter of trees upwind pay attention to the following:</i></p> <ul style="list-style-type: none"> <li>- <i>Make sure that the shelter will protect the whole height of the inflated balloon</i></li> <li>- <i>Make sure that the balloon is securely restrained.</i></li> <li>- <i>Be aware that as the balloon flies clear of the shelter the envelope may distort and lose lift that will have to be replaced by burning at once.</i></li> </ul>
-------------	--

<b>NOTE</b>	<i>Takeoff for night flights: Carry on the standard procedures, use the portable light when necessary.</i>
-------------	--

## 4.4 In-Flight Procedures

### 4.4.1 Regular In-flight Checks

<b>Envelope</b>	Check stability, mouth open, DS sealed
<b>Location</b>	Compare your position with a map, compare the actual path with the expected one, consider further steps or flight termination
<b>Fuel</b>	Check the amount of fuel available, estimate actual consumption and expected flight duration
<b>Instruments</b>	All values within limits
<b>Passengers</b>	Make sure everyone is comfortable with the flight
<b>Retrieve Crew</b>	Communicate your position and intentions when necessary

<b>NOTE</b>	<i>When you feel wind it indicates the balloon is flying through turbulence or wind shear and the envelope needs to be checked.</i>
-------------	---

<b>WARNING</b>	<i>Always check visually the parachute after each operation in flight.</i>
----------------	--

<b>CAUTION</b>	<i>Allow for much slower balloon response when using a whisper burner instead of the main burner system. Low fuel pressure and/or heavy loads further slow response. Exercise special care in keeping descent rates under control when using the whisper burner alone.</i>
----------------	--

### 4.4.2 Inflight venting

In-flight venting is a way of releasing of a hot air from an envelope during a flight. It is used to descend, stop a climb or to prevent the envelope from overheating. For some deflation systems this procedure differs from deflation/landing procedure. For in-flight venting see the table below:

Deflation system	OPEN - pull and hold	CLOSE - release
<b>Parachute</b> (up to s/n 2199)	red line	red line
<b>Paralite</b> (up to s/n 2199)		red line, pull white line for good seal*
<b>Parachute</b> (from s/n 2200)	red-white (RW) line	RW line
<b>Paralite</b> (from s/n 2200)		RW line, pull white line for good seal*
<b>Slide Vent</b> (2 control lines)		RW line
<b>Lite Vent, Slide Vent</b> (3 control lines)		RW line, pull white line for good seal*
<b>Smart Vent</b>		RW line

\* if necessary.



#### 4.4.3 Level Flight

Maintain level flight by regular heating with one burner unit at regular intervals. When the flight path is slightly wavy, put a burst just after passing the peak. When in slight climb do not heat but wait.

Certain conditions, generally associated with low ambient air densities, may cause flame instability after several seconds of continuous burner operation. Under these conditions, flameout can occur:

- There is a change in the sound of the burner flame - a „swoosh“ noise.

If burning is continued:

- The burner flame may decrease in size and velocity.

If burning is still continued:

- Burner flame and pilot lights may be extinguished.

Flameout can usually be avoided by ending the burn at the initial „swoosh“ sound and leaving the burner off for one or two seconds. Further „swoosh“ can be avoided by using short burns.

<b>CAUTION</b>	<i>Test long burns for flame instability before relying on them for arresting rapid descent or clearing obstacles.</i>
----------------	--

#### 4.4.4 Climb

<b>Space check</b>	Check the space above the balloon is clear (e.g. look through envelope window, shadows, ask ground crew or pilots flying nearby)
<b>Climb</b>	Initiate climb by a longer heating with single unit, then maintain desired rate of climbs by regular short burst.
<b>Level flight</b>	Terminate climb by a prolonged delay in heating. Stabilize the level flight by a short burst at the top of climb.

<b>CAUTION</b>	<i>Envelope temperature is considerably higher in climb than during level flight. Pay attention not to exceed the maximum allowable temperature.</i>
----------------	--

#### 4.4.5 Descent

<b>Space check</b>	Check the space below the balloon is clear.
<b>Descent</b>	Initiate descent by a prolonged delay in heating or by venting. When the desired rate of descent is almost reached, stabilize it by one longer heating and maintain it by short regular bursts. If the balloon rotates, keep facing the direction of flight.
<b>Level flight</b>	Terminate descent by an intense heating with one or two units, then wait for the reaction. If the balloon has a tendency to start climbing due to overheating, use venting and subsequent heating to restore level flight.

#### 4.4.6 Rapid Descent (over 3-4 m/s [600-800 ft/min])

<b>Preparation</b>	Check function of burners and the amount of fuel in the cylinders now connected. Increase amount of pilot flame (2-hose burners only). Check envelope temperature. Verify availability of backup means of ignition.
<b>Other steps are the same as for normal descent, with a more intense action to initiate and stop the descent.</b>	

#### 4.4.7 Contour Flying and Obstacle Clearance

Use short burst with one or two burner units to accurately control the vertical flight path. Always wait until the balloon starts to descend gently and then heat again. When climbing too fast, just wait. Approach obstacles not higher than 60% of the balloon height and heat soon enough to fly over it safely. Once over the obstacle, do not heat and wait until the balloon starts to descent. Follow the contour of open or cultivated fields.

Obstacle avoidance during every flight is paramount to safety. Obstacles such as power lines, antennas, etc., should be approached with sufficient altitude to ensure clearance. Descents should be avoided while passing over such obstacles. Level flight or slight ascent will allow the greatest margin of safety around such hazardous obstacles.

## 4.4.8 Fuel Management

**WARNING** *Make sure that every burner unit is usable during the final landing.*

Recommended fuel management procedures for 1-unit and 2-units burner:

- 2 fuel cylinders: The cylinder farther from the pilot to be consumed until last 35% remains, then switch to the other fuel cylinder until landing
- 3 fuel cylinders: The cylinder close to the pilot to be consumed until last 15% remains, then the farther cylinder consumed until 35% remain, then switch to the other fuel cylinder close to the pilot until landing.
- 4 or more fuel cylinders: Use one of the farther fuel cylinders until 15% of fuel remains, then proceed as for 3 fuel cylinders.
- Always use the fuel cylinders with vapor phase connected first.
- Start to prepare for landing no later than after connecting the last fuel cylinder.

For 3 or 4 burner units - adopt the procedure according to actual fuel tank setup.

**NOTE**

*Fuel should be drawn from only one tank at any one time for each burner to simplify securing fuel in the event of an emergency.*

**WARNING**

*When fuel quantity diminishes, so does fuel pressure. This decreases burner heat output and the capability for climbing to clear obstacles. With low pressure the pilot risks a hard landing and/or damage to avoid any possibility of contact with power lines or other dangerous obstacles. Beware of burner flame instability.*

## 4.4.9 Changing Fuel Cylinders

1. Verify correct function of the other burner unit (in case of Sirius – verify correct function of the other side of the burner unit).
2. Initiate a slight climb.
3. Close the fuel cylinder to be disconnected.
4. Burn the fuel in the hose to be disconnected by heating.
5. Reconnect hose fittings to another fuel cylinder, visually check tightness.
6. Open fuel supply valves on the newly connected cylinder, ignite the pilot burner, verify correct function of the burner unit.
7. Note the time of reconnection, reconsider fuel consumption and expected flight duration.

**WARNING**

*Reconnecting unempty fuel hoses is very dangerous. When Tema connector is used it is also very difficult. Always empty the fuel hoses before reconnecting them.*

## 4.4.10 Use of T-manifold

1. Shut off the used fuel cylinder, then open the full one. Only one cylinder may be opened at a time!
2. Verify correct function of the burner unit.
3. Note time of reconnection, reconsider fuel consumption and expected flight duration.

**CAUTION**

*Never have both the fuel tanks open at the same time!*

**WARNING**

*Only manifolds supplied by Kubíček Factory or another EASA approved balloon manufacturer may be used.*

#### 4.4.11 Dropping of Parachutists

##### Conditions for parachuting:

- The maximum balloon take-off weight must not be exceeded.
- The weight of parachutists that are to jump and their equipment must be taken into account in the pre-flight planning to ensure the balloon remains within applicable limits during the entire flight (Minimum Landing Weight!)
- All applicable national regulations must be complied with.
- Free fall parachuting is only permitted. Static line releases must not be used.
- Maximum number of parachutists to be released at one time is one.

The pilot must react to a sudden drop of weight when the parachutists exit. To prevent the balloon from an excessive rise the parachute is to be opened. It is also possible to drop the parachutists with the balloon in a moderate descent. The recommended value is 1 m/s (200 ft/min).

##### Dropping procedure:

<b>Preparation</b>	Parachutists sit on the basket top rim
<b>Unobstructed exit</b>	Parachutists are well free from control lines, fuel hoses or any other equipment
<b>Airspace check</b>	Airspace under the basket is free from any air traffic
<b>Dropping</b>	Parachutists leave the basket after the agreed pilot's signal
<b>Venting</b>	Vent enough to prevent undesired climb

#### 4.4.12 In-flight Checks for Night Flying

Carry on the standard procedures, use the portable light when necessary.

#### 4.4.13 Overheating of the Envelope - Temperature Streamer Drops during the Flight

<b>Burner</b>	Stop burning and then continue using short burns.
<b>Descent</b>	Descend to the minimum practical altitude and keep to low rates of climb and descents.
<b>Landing</b>	Land on a suitable landing field.

<b>CAUTION</b>	<i>Grab test the fabric if substantial envelope overheating is suspected. For details see the KB Maintenance Manual.</i>
----------------	--

## 4.5 Landing

### 4.5.1 Selection of Landing Site

Select a suitable landing site meeting these criteria:

- Large enough for a safe landing with regard to the actual wind
- **Free of power lines**, obstacles, animals, providing enough space for approach and landing
- No risk of mechanical turbulence, rotors and other disturbing influences. „False lift“ can be experienced on landing when encountering wind shear near the surface. When wind is felt in the basket on approach, it indicates a wind shear and „false lift“ is probable
- Enough space for packing the balloon and access of retrieve crew and car
- No risk of damage to property of third parties
- Choose a non-congested landing area

Once the landing site is chosen, plan the approach path with regard to the actual terrain and wind.

## 4.5.2 Approach

<b>Approach Path</b>	Follow your approach path using appropriate heating and venting, keep clear of obstacles. Look for the signs of wind shear
<b>Passengers</b>	Rebrief passengers about position for landing and other actions
<b>Retrieve Crew</b>	Inform the retrieve crew about your intentions
<b>Control Lines</b>	Within easy reach
<b>Pilot Restraint</b>	(If the pilot restraint harness is used) wear and adjust, connect the strap
<b>Burner and Fuel</b>	Verify function and amount of fuel
<b>Position lights (if fitted)</b>	Switch off and store
<b>Rotation Vent (if fitted)</b>	Keep the balloon and scoop facing forward using the RV
<b>Drop line (if needed)</b>	Prepare the drop line in advance for an imminent use. Attach the drop line to an envelope carabiner.
<b>Descent</b>	Establish and maintain descent to the selected landing area

**WARNING** *On approach to land the practice of brushing through tree tops to slow the speed of the balloon is not recommended. Tree lines hide power lines and this practice increases the possibility of a power line strike.*

**WARNING** *Balloons equipped with a rotation vent must be oriented before landing so that the basket touches the ground with its longer side first. The first contact with the basket corner or short side is dangerous.*

**WARNING** *WIND SHEAR ON LANDING It is critical that pilots recognize wind shear on approach to land. It is the major cause of hard landings, especially with heavily loaded balloons. When the top of the balloon goes through the wind shear, it first gives a lift which cancels the slow descent that the pilot has initiated on his approach. If the pilot does not recognize this phenomena, he will wait for the balloon to descend before firing the burner. The combination of the delay in firing the burner and the sudden loss of the „false lift“ will create a more rapid descent than anticipated. The loss of lift is created when the differential wind on the top of the envelope goes away as the balloon drops below the wind shear and the balloon speed is reduced to the lower wind.*

## 4.5.3 Landing

### Landing position

- Stay low in the basket and bend knees. Heads always below the upper rim of the basket.
- Stow all objects (cameras etc.), hold on the rope handles with both hands.
- Place as many passengers as possible to the rear side of the basket.
- In open baskets heavier persons need to be placed first in the direction of flight. Sideways position is the most favourable but difficult to achieve due to limited space. If the sideways position is not possible, the persons placed first should also be oriented backwards to the direction of flight.
- In case of a passenger travelling inside of the pilot’s compartment - use the rope handle for securing. It is allowed to use rope handle with one hand and the rim of the fuel tank with the other hand, if this would offer more stable position (considering the number and distribution of the fuel tanks and other factors).

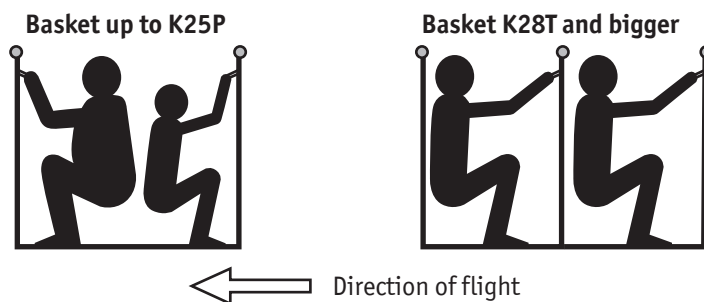

<b>Landing position</b>	Passengers must adopt landing position. Pilot must ensure passengers adopted correct landing position.						
<b>Final Approach</b>	Descend to a height of approximately 1 m (3 ft) above ground, make a final burn to slow the descent if appropriate.						
<b>Drop line (if needed)</b>	Check the attachment and drop to the chase crew, if it is safe so.						
<b>Burner Shutoff</b>	Turn off all burners and pilot flames when no further heating is required. Shut off all fuel supplies on the cylinders and vent all hoses.						
<b>Venting</b>	<table border="0"> <tr> <td>Parachute/ Paralite (s/n up to 2199)</td> <td>Pull the red line just prior to touchdown.</td> </tr> <tr> <td>Parachute/ Paralite (from s/n 2200)</td> <td>Pull the red-white line just prior to touchdown.</td> </tr> <tr> <td>SV, SLV, LV</td> <td>Pull the red line just prior to touchdown.</td> </tr> </table>	Parachute/ Paralite (s/n up to 2199)	Pull the red line just prior to touchdown.	Parachute/ Paralite (from s/n 2200)	Pull the red-white line just prior to touchdown.	SV, SLV, LV	Pull the red line just prior to touchdown.
Parachute/ Paralite (s/n up to 2199)	Pull the red line just prior to touchdown.						
Parachute/ Paralite (from s/n 2200)	Pull the red-white line just prior to touchdown.						
SV, SLV, LV	Pull the red line just prior to touchdown.						
<b>Touchdown</b>	Inform passengers just prior to the contact with the ground.						
<b>Venting</b>	Keep venting until the balloon stops safely.						

**WARNING**

*It is MANDATORY to maintaining the flight trajectory parallel to the surface during the final approach. Not levelling the flight before touchdown is extremely dangerous and may lead to injuries.*

**WARNING**

*When attaching and dropping the drop line, ensure that it is free from all fuel hoses, control lines and rigging. Do not allow the crew to catch the drop line during its fall. It should hit the ground free of obstructions.*

**4.5.4 Actions After Landing**

1.	All persons remain in the basket.						
2.	The pilot verifies the terrain is suitable for packing and access of the retrieve crew or consider walking the inflated balloon to a more convenient place if necessary.						
3.	Passengers leave basket on pilot's instructions.						
4.	Turn the balloon so that the scoop is facing down wind. Detach the crown line. Instruct the crew where to lay the envelope.						
5.	<table border="0"> <tr> <td>Parachute/ Paralite (s/n up to 2199)</td> <td>Open the DS completely by the red line and deflate the envelope.</td> </tr> <tr> <td>Parachute/ Paralite (from s/n 2200)</td> <td>Open the DS completely by the red-white line and deflate the envelope.</td> </tr> <tr> <td>SV, SLV, LV</td> <td>Open the DS completely by the red line and deflate the envelope.</td> </tr> </table>	Parachute/ Paralite (s/n up to 2199)	Open the DS completely by the red line and deflate the envelope.	Parachute/ Paralite (from s/n 2200)	Open the DS completely by the red-white line and deflate the envelope.	SV, SLV, LV	Open the DS completely by the red line and deflate the envelope.
Parachute/ Paralite (s/n up to 2199)	Open the DS completely by the red line and deflate the envelope.						
Parachute/ Paralite (from s/n 2200)	Open the DS completely by the red-white line and deflate the envelope.						
SV, SLV, LV	Open the DS completely by the red line and deflate the envelope.						
6.	Crown crew pulls the crown line downwind, stabilizing the envelope and helping to lay it in the desired direction, clear of burners and obstacles. Other crew members can help to keep the envelope from draping over trees or bushes and assist it in coming down.						
7.	Empty the envelope of air by folding it into a long line and expelling the air towards the crown.						

## 4.5.5 Packing of the Envelope

1. Once the envelope lies on the ground, reconnect the aft envelope carabiners to the forward ones and attach them to the outer basket handles.
2. Release the control lines and store them in the envelope.
3. Pull the DS panel to the crown ring.
4. Start pack the envelope into a “sausage” shape from the mouth towards the top, expelling the remaining air through the DS aperture. The crown crew holds the DS aperture open if necessary.
5. Pack the crown line and place it on the fabric together with top load tapes.
6. Pack the envelope into the bag starting at the top end. At the mouth the envelope carabiners are to be put into their bag and together with flying wires wrapped into the scoop fabric so that no metal part comes in contact with the envelope fabric.

<b>CAUTION</b>	<i>If the envelope is damp or wet it must be dried as soon as possible. Storage when wet can cause severe damage to the envelope and especially its artwork.</i>
----------------	--

## 4.5.6 Packing of the Bottom End

1. Verify all fuel hoses are vented from remaining fuel.
2. Wait till the burner coils are cooled down.
3. Disconnect them from the fuel cylinder fittings. Detach the burner support rod padding and place hoses conveniently onto the burner or burner frame. Observe the minimum radius of bend.
4. Detach basket carabiners from the burner frame and put the basket wires through the basket inner handles with all carabiners kept at the ends.
5. Fix the burner units to the burner frame.
6. Remove the burner frame from the support rods. Place it into its bag, if available, and hang it in the basket.
7. Check that all tank valves are in the closed position.

<b>NOTE</b>	<i>For more details how to pack the collapsible baskets K10C and K13C refer to Appendix 8.</i>
-------------	--

<b>CAUTION</b>	<i>Always vent the fuel hoses and T-manifolds to prevent damage to the hoses. Always keep the minimum hose bend radius 90 mm. See Appendix 5 for guidance.</i>
----------------	--

<b>WARNING</b>	<i>Do not vent raw propane. Don't use fuel for cooling the coils.</i>
----------------	---

<b>WARNING</b>	<i>You can suffer severe burns if you touch the burner coil when it is hot.</i>
----------------	---

## 4.5.7 Loading, Leaving the Landing Site

1. Load all the equipment into the vehicle or onto a trailer and verify nothing is left behind.
2. Secure all the balloon parts to avoid any movement.
3. Record the flight in the balloon log book and pilot's log book.
4. If necessary, verify and note any damage to the landing site, balloon or retrieve vehicle.

<b>NOTE</b>	<i>It is not advised to transport burners erected (on the basket). As such transport can cause damage to the burner.</i>
-------------	--

<b>WARNING</b>	<i>Do not transport any persons in the basket!</i>
----------------	--

#### 4.5.8 Special Cases of Landing

The following cases of landing, although considered normal, require a more careful pilotage compared to normal landing:

##### Landing onto a Downhill Terrain

Make a very gentle touchdown and keep the basket from flipping downhill.

##### Landing onto an Uphill Terrain

Make a very gentle touchdown in a moderate climb.

##### Landing Just Behind an Obstacle

Approach with a level flight path with sufficient distance from the obstacle. In case of a single obstacle keep level with its top and do not descent below it. Fly above the obstacle and vent to initiate a steep descent just after passing over it.

**WARNING** Verify the area behind the obstacle is clear of power lines before initiating a descent!

### 4.6 Tethered Operations

#### 4.6.1 Tethering Site

An open area with no overhead cables or obstructions is required. It must be large enough to allow inflation and deflation of the envelope and provide strong tie-off points or access for vehicles. There must be facilities for crowd control and the area downwind must be clear of obstructions in case the balloon breaks away and has to be flown free.

#### 4.6.2 Rigging the Balloon

The best arrangement for a tether is a low tripod arrangement with three tether lines with two upwind and one downwind.

Two main ropes of the same length are anchored on the upwind side to the tethering lugs on the burner frame (if such frame is used) or directly to the envelope carabiners, when the burner frame without lugs is used. These ropes provide the main resistance to movement. The upwind ropes must be firmly attached to strong points on the ground and spread so that the angle between them is no more than 90 degrees. The distance between the basket and tether point (dimension R in the picture) and is to be equal or greater than the desired altitude (H).

The third rope is attached to the downwind side of the balloon to the burner frame lug or the envelope carabiner. It may either be fixed to a car or truck or held by a crew of up to three people. This third rope is used to restrict the height of the tethered balloon. If fixed to a vehicle this it may be moved away from the balloon to restrict the height of the tether.

Ropes used for tethering should have a minimum strength of 4 000 kg (8 800 lb) and should be inspected before each event. Where carabiners are required in the tethering system 4 000 kg (8 800 lb) carabiners are to be used.

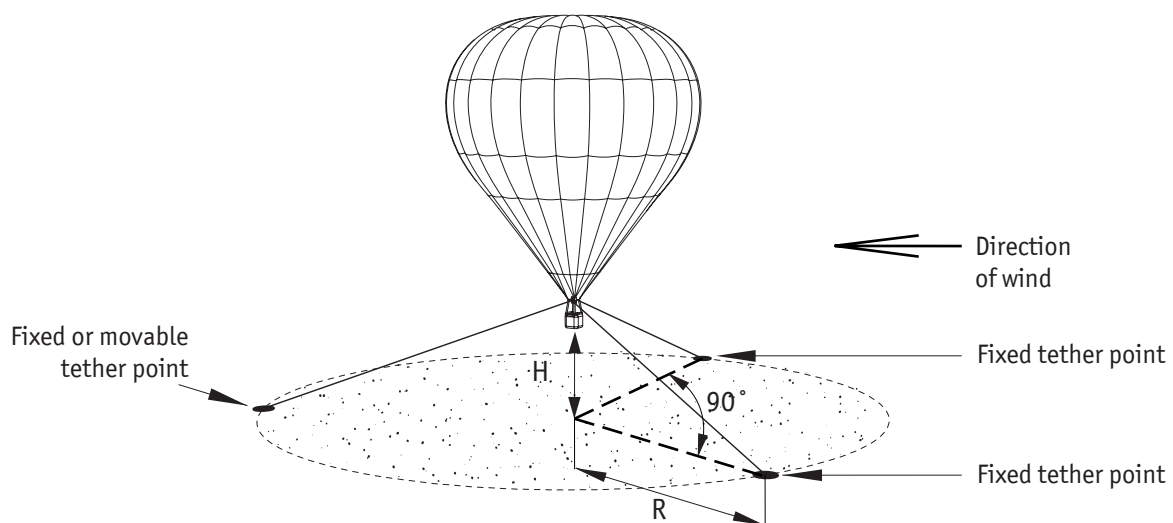

Tether layout

The length of ropes are to be appropriately adjusted so that all three ropes carry the load when the balloon is in desired position and height. If the wind increases so that the controllability of the balloon is limited, then the height is to be lowered. If the wind speed or gusting exceeds the limits in section 2 (Operational Limitations) of this Manual and/or the controllability is very poor, then the envelope must be deflated. The actual wind speed (read from a hand-held anemometer) must be available to the pilot during the entire tethered flight.

<b>WARNING</b>	<i>The minimum strength of fixed tether points for the main ropes is the same as for attaching the quick release rope (see para 4.3.6). When the downwind rope gets taut the pilot must not continue heating.</i>
----------------	---

<b>WARNING</b>	<i>The basket lugs are to be used for quick release attachment during takeoff and must not be used for continuous tethering!</i>
----------------	--

<b>WARNING</b>	<i>The quick release must never be used during tethered flight.</i>
----------------	---

<b>WARNING</b>	<i>The pilot should instruct the crew members to keep spectators away from the basket, tether lines and tie-off points or vehicles. Avoid tethering without effective crowd control. Always consider bystanders as unaware of the risks involved with tethering.</i>
----------------	--

<b>CAUTION</b>	<i>The drop line installed in the basket shall not be used as a tethering line.</i>
----------------	---

<b>NOTE</b>	<i>Be aware that tethering in windy conditions puts considerable stress on the balloon, tethering equipment and tether points. If any of the equipment is suspected to have been overstressed then the balloon must be deflated.</i>
-------------	--

## 4.7 Refuelling

### 4.7.1 General Precautions When Dealing With Fuel and Manipulating Fuel Cylinders

<b>WARNING</b>	<i>No smoking or operation of electrical equipment, or engines within 6 metres of the refuelling operation. Remove all strikers or ignition sources from the basket. Wear leather gloves and have a fire extinguisher readily available. REFUEL OUTDOORS ONLY!</i>
----------------	--

<b>WARNING</b>	<i>Refuelling and any manipulation of fuel cylinders must be carried out with extra care and by knowledgeable personnel only in accordance with standard practices for handling propane, and supervised by the pilot. Propane, butane and LPG are highly flammable. The following instructions must be followed and any national regulations fulfilled.</i>
----------------	---

**Dos:**

- Wear strong protective gloves as a protection from possible burns or frostbites from evaporating fuel. The gloves must also allow for an easy manipulation with fittings and valves.
- Avoid wearing clothes made of synthetic material to reduce the risk of static spark.
- At least one fire extinguisher must be available.
- The fuel cylinders and supply source must be electrically grounded when refueling.
- Keep away all sources of fire, heat, ignition, lighters, matches, smoking, naked lights, live electric or radio equipment, or mobile telephones.
- Keep away all persons not directly involved in the refueling.

**Don'ts:**

- Do not refuel cylinders in the basket.
- Do not refuel cylinders in an enclosed area (like a closed trailer or a van) or near any hollows, pits, or anywhere the vapor could accumulate.
- Do not refuel more than one cylinder at a time.



#### 4.7.2 Refuelling Procedure

1. Connect the cylinder with the refuelling hose.
2. Open the maxfill valve on the fuel cylinder just enough to hear the gas escaping.
3. Open the liquid valve on the cylinder.
4. Open the supply valve on the source tank.
5. Start the pump (if fitted).
6. Check the fuel gauge - fuel indicator moves within 0 - 40% (if not contact your repair station).
7. When the flow from the maxfill valve changes from vapor to liquid, turn the liquid valve on the cylinder off immediately. Close the maxfill valve and turn the pump off.
8. Vent the refuelling hose and empty the liquid valve on the cylinder by depressing its central self-sealing spigot.

**WARNING**

*Do not overfill the fuel tank at any case! Do not exceed the safe working pressure specified in the fuel cylinder index plate!*

**WARNING**

*Do not fill fuel tanks or open the liquid level gauge valve with tanks in a polyethylene basket or wicker basket which has been lined with any material which would restrict airflow through the basket. Failure to heed this warning may result in serious injury caused by a flash fire.*

**NOTE**

*Filling by weight should not exceed 0.42 kg/l of the water capacity. See Chapter 8.*

**CAUTION**

*The fuel cylinder can be used even when the fuel gauge is not working correctly (the fuel indicator does not move etc.). Such fuel cylinder CANNOT be counted in the Minimum Fuel Quantity as specified in table in Chapter 2.3.*

#### 4.7.3 Pressurisation of Fuel Cylinders

In order to increase fuel pressure in cold conditions fuel cylinders may be pressurised with nitrogen.

The nitrogen must be supplied from a regulated source providing a pressure of between 0 - 10 bar (0-145 psi) and an indication of the pressure in the fuel cylinder.

The nitrogen must be handled in accordance with the supplier's instructions.

Nitrogen is supplied to the fuel cylinders that have been previously fueled. Nitrogen is supplied through the liquid take off until the desired pressure is reached.

**WARNING**

*No gas other than nitrogen may be used for pressurisation! Never use air or oxygen!*

**CAUTION**

*The maximum fuel cylinder pressure after pressurizing must not be greater than 10 bar (145 psi). The maximum fuel cylinder pressure must not be greater than 7 bar (100 psi) if the cylinder is to be stored in a pressurised state.*

If vapor pilot lights are to be used, then sufficient master cylinders must be left unpressurized and identifiable so that nitrogen is not fed to the pilot lights.

Cylinders pressurized with nitrogen should not be used for vapor pilot lights.

Fuel cylinders should be pressurized shortly before they are to be used and labeled to indicate that they are pressurized. If they are not used soon after pressurizing then the pressure in these cylinders should be reduced to a maximum of 7 bar (100 psi) by opening the maxfill valve. When venting in this way the same precautions are to be taken as for refueling fuel cylinders.

In addition to the above instructions, the applicable national and local requirement for safety, handling and storage of pressurized gases and pressure cylinders are to be observed.

INTENTIONALLY LEFT BLANK

## SECTION 5 - WEIGHT

### 5.1 Introduction

This section provides guidance for establishing the flight weight range within which the balloon can be safely flown. The balloon's lifting capacity is mainly affected by ambient air temperature and flight altitude. Higher ambient air temperature and higher altitude lead to lower lifting capacity and vice versa.

### 5.2 Loading Chart and Table

Before each flight the take-off mass of the balloon must be calculated to see that it does not exceed the Total Permitted Lift.

The Total Permitted Lift depends on:

- envelope volume
- flight altitude
- ambient air temperature

<b>NOTE</b>	<i>When exceeding the Total Permitted Lift in flight the temperature streamer is likely to drop.</i>
-------------	--

<b>NOTE</b>	<i>Weight limitations specified in Chapter 2. must be observed as well.</i>
-------------	---

#### 5.2.1 Instruction for Determining Allowable Weight Range Using the Loading Chart and Table

1. Find the actual take-off weight as a sum of the weight of the entire balloon, persons in the basket, fuel and all other equipment to be carried on board. The weight of the air inside the balloon shall not be considered.
2. Decide on the maximum desired flight altitude and determine the air temperature at this altitude. If the temperature is not known, assume a standard temperature decrease of 0.65°C/100m (3.56°F/1000ft).
3. Read the number of Lift Units per 1000 cubic feet from the Loading Chart. Start from the actual altitude temperature on the horizontal axis, go vertically until reaching the curve for the desired altitude. From this intersection continue horizontally to read the actual value of Lift Units.
4. In the Loading Table find the appropriate value of the Total Permitted Lift.
5. Compare the take-off weight to the Total Permitted Lift and MTOW (or RMTOW if applicable). The balloon can only be flown if the actual take-off weight remains within these limits.

<b>NOTE</b>	<i>The Loading Chart and Loading Table are based on static lift with the maximum operational allowed envelope's internal temperature that allows for moderate rate of climb without overheating the envelope. When flying a balloon at, or close to, its maximum lift care must be taken not to overheat the envelope by intense heating.</i>
-------------	---

<b>CAUTION</b>	<i>In addition to the above weight assumptions the maximum loading capacity of the basket must be observed as well! See section 2.10 of this manual.</i>
----------------	--

### 5.3 Flying in a Temperature Inversion

The Loading Chart presumes that the temperature decreases with height according to ISA. When the temperature increases with height instead of decreasing this is called a temperature inversion. A temperature inversion happens frequently in the early morning, particularly if there has been a clear sky overnight.

To prevent overheating the balloon when flying in an inversion, enter the chart with either the anticipated temperature at your launch height at mid day or the known temperature at a specific height above the inversion.

## 5.4 Sample Calculations

Dot-and-dashed line shows the following sample calculation.

### Example

- Your balloon is a BB20 (71 200 cu ft). Calculate the take-off weight as a sum of the weight of the complete balloon (calculate with exact weights of each assembly written on the part itself - the envelope ID plate, the basket ID plate and the burner gimbal block, fuel cylinder ID plate), fuel, occupants and equipment.
- The balloon will be flown at a maximum altitude of 6 000 ft and your weather briefing has told you that the temperature at this height will be 6°C.
- Enter the Loading Chart at 6°C on the bottom line and go up until you reach the 6 000 ft curve. From this point travel left parallel to the horizontal lines until you reach the left scale at 16.5.
- Decide whether you want an answer in either kg or lb and enter the appropriate Loading Table with 16.5 along the top line. You will have to interpolate between 16 and 17. Go vertically downwards until you reach the horizontal line for a BB20. The result is 533 kg (1175 lb).
- The take-off weight must remain below 533 kg (1175 lb) and MTOW for the BB20 model. If yes, the balloon can be flown in the actual condition.

<b>NOTE</b>	<i>For weight calculation assume all fuel cylinders onboard as full. Fuel cylinder ID plate contains information about its empty weight as well as full weight with propane and full weight with LPG.</i>
<b>NOTE</b>	<i>Pay particular attention to observing the MTOW at low temperatures. In no case may the intersection of temperature and desired flight altitude lie above the chart. This would lead to exceeding the MTOW.</i>

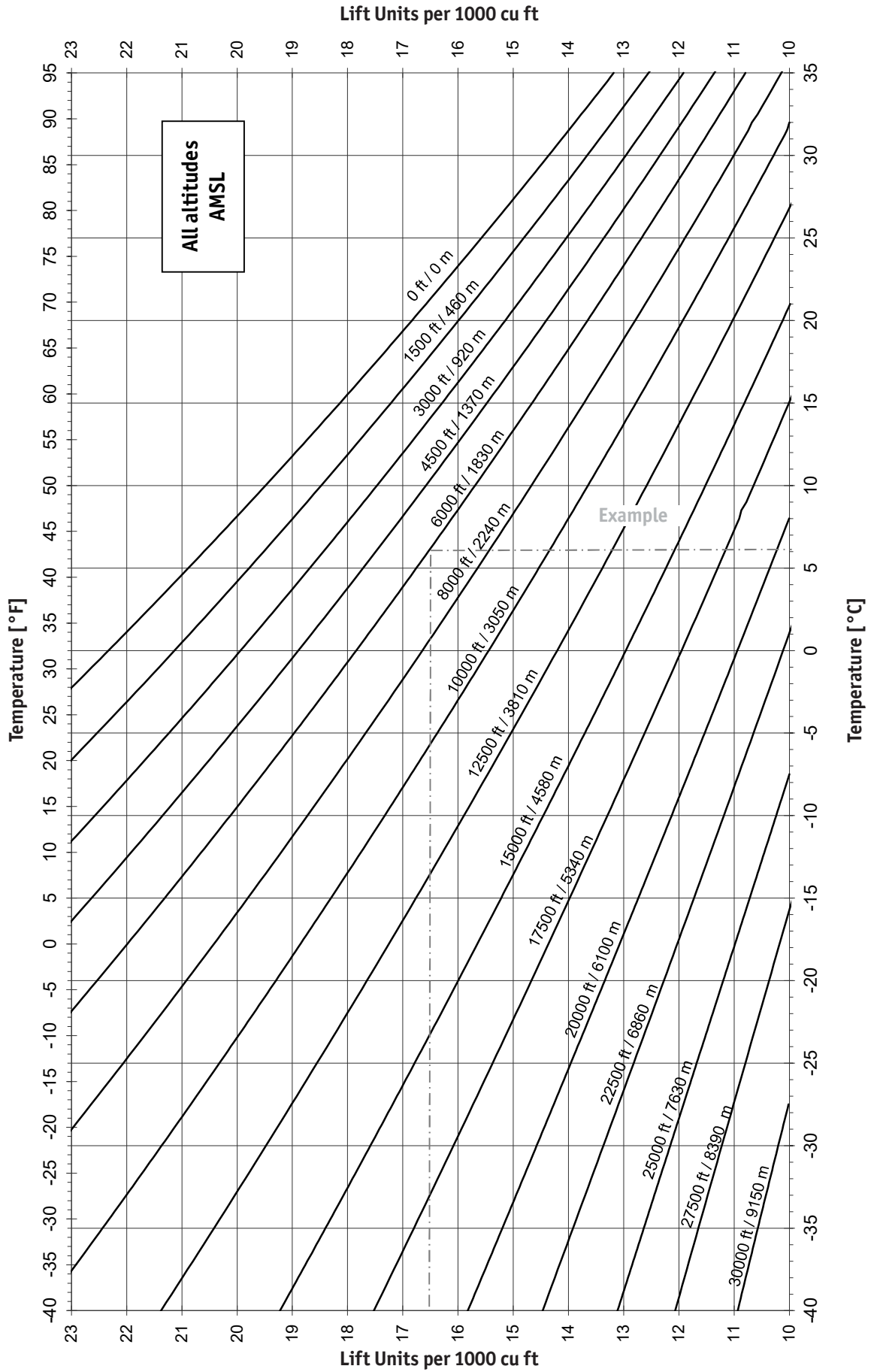

## 5.6 Loading Table

Maximum balloon lifting capacity [kg]														
Envelope	Lift Units per 1000 cu ft													
	10	11	12	13	14	15	16	17	18	19	20	21	22	23
BB9, BB9E, BB9EF	145	160	175	189	204	218	233	247	262	276	291	295	295	295
BB12, BB12E, BB12EF	194	213	233	252	271	291	310	330	349	368	385	385	385	385
BB14XR	226	249	271	294	317	339	362	385	407	420	420	420	420	420
BB16, BB16E, BB16EF, BB16XR	259	284	310	336	362	388	414	439	465	470	470	470	470	470
BB17GP, BB17XR	272	299	326	354	381	408	435	462	490	495	495	495	495	495
BB18E	291	320	349	378	407	436	465	494	524	550	550	550	550	550
BB18XR	291	320	349	378	407	436	465	494	524	553	570	570	570	570
BB20, BB20E, BB20ED	323	355	388	420	452	485	517	549	582	614	630	630	630	630
BB20GP, BB20XR	323	355	388	420	452	485	517	549	582	614	646	679	711	730
BB22E, BB22ED, BB22M	355	391	427	462	498	533	569	604	640	675	680	680	680	680
BB22, BB22D, BB22N, BB22Z	355	391	427	462	498	533	569	604	640	675	711	730	730	730
BB22XR	355	391	427	462	498	533	569	604	640	675	711	747	780	780
BB26E, BB26ED, BB26M	420	462	504	546	588	630	672	714	730	730	730	730	730	730
BB26, BB26D, BB26N, BB26Z, BB26XR	420	462	504	546	588	630	672	714	756	798	840	840	840	840
BB30E, BB30ED, BB30M	485	533	582	630	679	727	776	824	840	840	840	840	840	840
BB30D, BB30N, BB30Z, BB30XR	485	533	582	630	679	727	776	824	873	921	945	945	945	945
BB34E, BB34ED	549	604	659	714	769	824	879	934	945	945	945	945	945	945
BB34D, BB34Z	549	604	659	714	769	824	879	934	989	1 040	1 040	1 040	1 040	1 040
BB37D, BB37N, BB37Z	598	658	717	777	837	897	957	1 016	1 076	1 136	1 150	1 150	1 150	1 150
BB40D, BB40Z	646	711	776	840	905	969	1 034	1 099	1 163	1 228	1 293	1 310	1 310	1 310
BB42D, BB42Z	687	755	824	893	961	1 030	1 099	1 167	1 236	1 305	1 373	1 410	1 410	1 410
BB45D, BB45N, BB45Z	727	800	873	945	1 018	1 091	1 163	1 236	1 309	1 382	1 454	1 520	1 520	1 520
BB51D, BB51Z	824	906	989	1 071	1 154	1 236	1 318	1 401	1 483	1 566	1 648	1 690	1 690	1 690
BB60D, BB60N, BB60Z	969	1 066	1 163	1 260	1 357	1 454	1 551	1 648	1 745	1 842	1 939	1 940	1 940	1 940
BB64Z	1 034	1 138	1 241	1 344	1 448	1 551	1 655	1 758	1 861	1 965	2 068	2 100	2 100	2 100
BB70D, BB70Z	1 131	1 244	1 357	1 470	1 583	1 697	1 810	1 923	2 036	2 149	2 262	2 300	2 300	2 300
BB78Z	1 260	1 386	1 512	1 638	1 764	1 890	2 017	2 143	2 269	2 395	2 521	2 600	2 600	2 600
BB85D, BB85Z	1 373	1 511	1 648	1 785	1 923	2 060	2 197	2 335	2 472	2 610	2 747	2 820	2 820	2 820
BB92Z	1 487	1 635	1 784	1 933	2 081	2 230	2 378	2 527	2 676	2 824	2 973	3 000	3 000	3 000
BB100D, BB100Z	1 603	1 763	1 924	2 084	2 244	2 405	2 565	2 725	2 886	3 046	3 200	3 200	3 200	3 200
BB105P	1 697	1 866	2 036	2 206	2 375	2 545	2 715	2 884	3 054	3 224	3 393	3 500	3 500	3 500
BB106P	1 713	1 884	2 055	2 227	2 398	2 569	2 740	2 912	3 083	3 254	3 426	3 500	3 500	3 500
BB113P	1 826	2 008	2 191	2 374	2 556	2 739	2 921	3 104	3 287	3 469	3 600	3 600	3 600	3 600
BB120P	1 939	2 133	2 327	2 521	2 715	2 908	3 102	3 296	3 490	3 684	3 700	3 700	3 700	3 700
BB130P	2 101	2 311	2 521	2 731	2 941	3 151	3 361	3 571	3 781	3 991	4 200	4 200	4 200	4 200
BB142P	2 276	2 504	2 732	2 959	3 187	3 415	3 642	3 870	4 098	4 325	4 500	4 500	4 500	4 500
BB150P	2 405	2 645	2 886	3 126	3 367	3 607	3 847	4 088	4 328	4 569	4 800	4 800	4 800	4 800
BB184P	2 950	3 245	3 540	3 835	4 130	4 425	4 720	5 015	5 095	5 095	5 095	5 095	5 095	5 095

Maximum balloon lifting capacity [lb]														
Envelope	Lift Units per 1000 cu ft													
	10	11	12	13	14	15	16	17	18	19	20	21	22	23
BB9, BB9E, BB9EF	320	352	384	416	448	481	513	545	577	609	641	650	650	650
BB12, BB12E, BB12EF	427	470	513	555	598	641	683	726	769	812	849	849	849	849
BB14XR	498	548	598	648	698	747	797	847	897	926	926	926	926	926
BB16, BB16E, BB16EF, BB16XR	570	626	683	740	797	854	911	968	1 025	1 036	1 036	1 036	1 036	1 036
BB17GP, BB17XR	599	659	719	779	839	899	959	1 019	1 079	1 090	1 090	1 090	1 090	1 090
BB18E	641	705	769	833	897	961	1 025	1 089	1 153	1 211	1 211	1 211	1 211	1 211
BB18XR	641	705	769	833	897	961	1 025	1 089	1 153	1 217	1 256	1 256	1 256	1 256
BB20, BB20E, BB20ED	712	783	854	925	997	1 068	1 139	1 210	1 281	1 353	1 389	1 389	1 389	1 389
BB20GP, BB20XR	712	783	854	925	997	1 068	1 139	1 210	1 281	1 353	1 424	1 495	1 566	1 609
BB22E, BB22ED, BB22M	783	861	940	1 018	1 096	1 175	1 253	1 331	1 410	1 488	1 498	1 498	1 498	1 498
BB22, BB22D, BB22N, BB22Z	783	861	940	1 018	1 096	1 175	1 253	1 331	1 410	1 488	1 566	1 609	1 609	1 609
BB22XR	783	861	940	1 018	1 096	1 175	1 253	1 331	1 410	1 488	1 566	1 644	1 720	1 720
BB26E, BB26ED, BB26M	925	1 018	1 111	1 203	1 296	1 388	1 481	1 573	1 609	1 609	1 609	1 609	1 609	1 609
BB26, BB26D, BB26N, BB26Z, BB26XR	925	1 018	1 111	1 203	1 296	1 388	1 481	1 573	1 666	1 758	1 852	1 852	1 852	1 852
BB30E, BB30ED, BB30M	1 068	1 175	1 281	1 388	1 495	1 602	1 709	1 815	1 852	1 852	1 852	1 852	1 852	1 852
BB30D, BB30N, BB30Z, BB30XR	1 068	1 175	1 281	1 388	1 495	1 602	1 709	1 815	1 922	2 029	2 083	2 083	2 083	2 083
BB34E, BB34ED	1 210	1 331	1 452	1 573	1 694	1 815	1 936	2 057	2 083	2 083	2 083	2 083	2 083	2 083
BB34D, BB34Z	1 210	1 331	1 452	1 573	1 694	1 815	1 936	2 057	2 178	2 291	2 291	2 291	2 291	2 291
BB37D, BB37N, BB37Z	1 317	1 449	1 580	1 712	1 844	1 975	2 107	2 239	2 371	2 502	2 535	2 535	2 535	2 535
BB40D, BB40Z	1 424	1 566	1 709	1 851	1 993	2 136	2 278	2 420	2 563	2 705	2 848	2 885	2 885	2 885
BB42D, BB42Z	1 513	1 664	1 815	1 967	2 118	2 269	2 420	2 572	2 723	2 874	3 026	3 109	3 109	3 109
BB45D, BB45N, BB45Z	1 602	1 762	1 922	2 082	2 242	2 403	2 563	2 723	2 883	3 043	3 203	3 351	3 351	3 351
BB51D, BB51Z	1 815	1 997	2 178	2 360	2 541	2 723	2 904	3 086	3 268	3 449	3 631	3 726	3 726	3 726
BB60D, BB60N, BB60Z	2 136	2 349	2 563	2 776	2 990	3 203	3 417	3 631	3 844	4 058	4 277	4 277	4 277	4 277
BB64Z	2 278	2 506	2 734	2 961	3 189	3 417	3 645	3 873	4 100	4 328	4 556	4 626	4 626	4 626
BB70D, BB70Z	2 492	2 741	2 990	3 239	3 488	3 737	3 987	4 236	4 485	4 734	4 983	5 071	5 071	5 071
BB78Z	2 776	3 054	3 332	3 609	3 887	4 165	4 442	4 720	4 997	5 275	5 553	5 727	5 727	5 727
BB85D, BB85Z	3 026	3 328	3 631	3 933	4 236	4 538	4 841	5 143	5 446	5 748	6 051	6 217	6 217	6 217
BB92Z	3 275	3 602	3 930	4 257	4 585	4 912	5 239	5 567	5 894	6 222	6 549	6 608	6 608	6 608
BB100D, BB100Z	3 531	3 885	4 238	4 591	4 944	5 297	5 650	6 003	6 357	6 710	7 055	7 055	7 055	7 055
BB105P	3 737	4 111	4 485	4 859	5 232	5 606	5 980	6 354	6 727	7 101	7 475	7 709	7 709	7 709
BB106P	3 773	4 150	4 528	4 905	5 282	5 659	6 037	6 414	6 791	7 169	7 546	7 709	7 709	7 709
BB113P	4 022	4 424	4 827	5 229	5 631	6 033	6 435	6 838	7 240	7 642	7 930	7 930	7 930	7 930
BB120P	4 271	4 698	5 126	5 553	5 980	6 407	6 834	7 261	7 688	8 115	8 150	8 150	8 150	8 150
BB130P	4 627	5 090	5 553	6 015	6 478	6 941	7 404	7 866	8 329	8 792	9 252	9 252	9 252	9 252
BB142P	5 015	5 516	6 018	6 519	7 021	7 522	8 023	8 525	9 026	9 528	9 913	9 913	9 913	9 913
BB150P	5 297	5 827	6 357	6 886	7 416	7 946	8 476	9 005	9 535	10 065	10 574	10 574	10 574	10 574
BB184P	6 498	7 148	7 797	8 447	9 097	9 747	10 397	11 046	11 224	11 224	11 224	11 224	11 224	11 224

**NOTE**

Values of the lifting capacity for the highest Lift Units are modified so that the balloon MTOW cannot be exceeded.

INTENTIONALLY LEFT BLANK



## SECTION 6 - BALLOON AND SYSTEMS DESCRIPTION

### 6.1 Introduction

This section provides description of the standard component parts and assemblies that make up the balloon system. A complete list of envelopes, baskets and burners is provided in Section 8. The approved combination of equipment is provided in Section 2.

### 6.2 Envelopes

Envelopes are of sewn construction made either from polyester or polyamide fabric and a system of load tapes. The fabric is coated to be airtight. Vertical load tapes take the load from the basket. At the top the vertical load tapes are secured to the crown ring, at the lower end there is a loop to which stainless steel or kevlar flying wires carrying the basket are attached. Where the flying wire and load tape loop are joined, they are covered by a protective sleeve. horizontal load tapes act as rip-stoppers. The envelope mouth and scoop panels are made from nomex fire resistant fabric.

The envelopes are always fitted with a deflation system that provides for a controlled venting of hot air during flight and landing.

Each envelope is also equipped with a crown line connected to the crown ring . The crown line is used to control the envelope during inflation and deflation.

All envelopes also have a temperature streamer and a tempilabel to indicate the maximum temperature.

The envelope can be fitted with a rotation vent which allows for a controlled rotation of the entire balloon during flight and for its proper orientation when landing.

### 6.3 Envelope Models

#### 6.3.1 Natural Shaped Envelopes

The BB type includes a variety of models differing in size, general geometry, orientation of the fabric, number of gores, their curvature and most suitable use. The envelopes models designated O, E, N, Z, GP, M, XR, P, D and ED.

A full description of envelope models is found at Kubíček Factory website [www.kubicekballoons.com/envelopes](http://www.kubicekballoons.com/envelopes). The controls of envelope Deflation systems are the same, irrespective of the model.

Some envelopes can be equipped with inflatable appendices, which can be equipped with deflation openings.

#### 6.3.2 Special Shapes

The special shaped envelopes (type BB-S) are typically made to replicate products or characters. Each model has its own supplement to this Manual which states its description, limitations and other possible peculiarities.

## 6.4 Envelope Deflation Systems and Equipment

All deflation systems have control lines that are operated by the pilot in order to open vent panel and release hot air from the envelope. The line to be used inflight is coloured red-white and the vent panel will automatically reseal itself after releasing the red-white line. The control line to be used ONLY for landing (see chapters 3 and 4 of this Manual) is red in colour.

**CAUTION** Parachutes and Paralites of envelopes with s/n up to 2199 (included) are fitted with RED LINE instead of red-white one.  
Only in case of these envelopes the red line may be used also for inflight venting, because no red-white line is available.

**WARNING** Except in an emergency, opening the Slide Vent, Smart Vent, Lite Vent or Rip Panel with the red line is prohibited if the underside of the basket is higher than 2 m (6.5 ft) above the ground.

### 6.4.1 Parachute

The Parachute is a simple deflation taking form of a circular parachute-style panel, sealing a circular opening (vent aperture) in the top of the envelope from the inside. The Parachute panel is held in position by inner overpressure and centered by centralizing lines which join its edge to the inside surface of the envelope.

Velcro tabs are sewn at the edge of vent aperture and to the Parachute.

The RED-WHITE line\* is used for venting. When released the Parachute resets itself by internal overpressure.

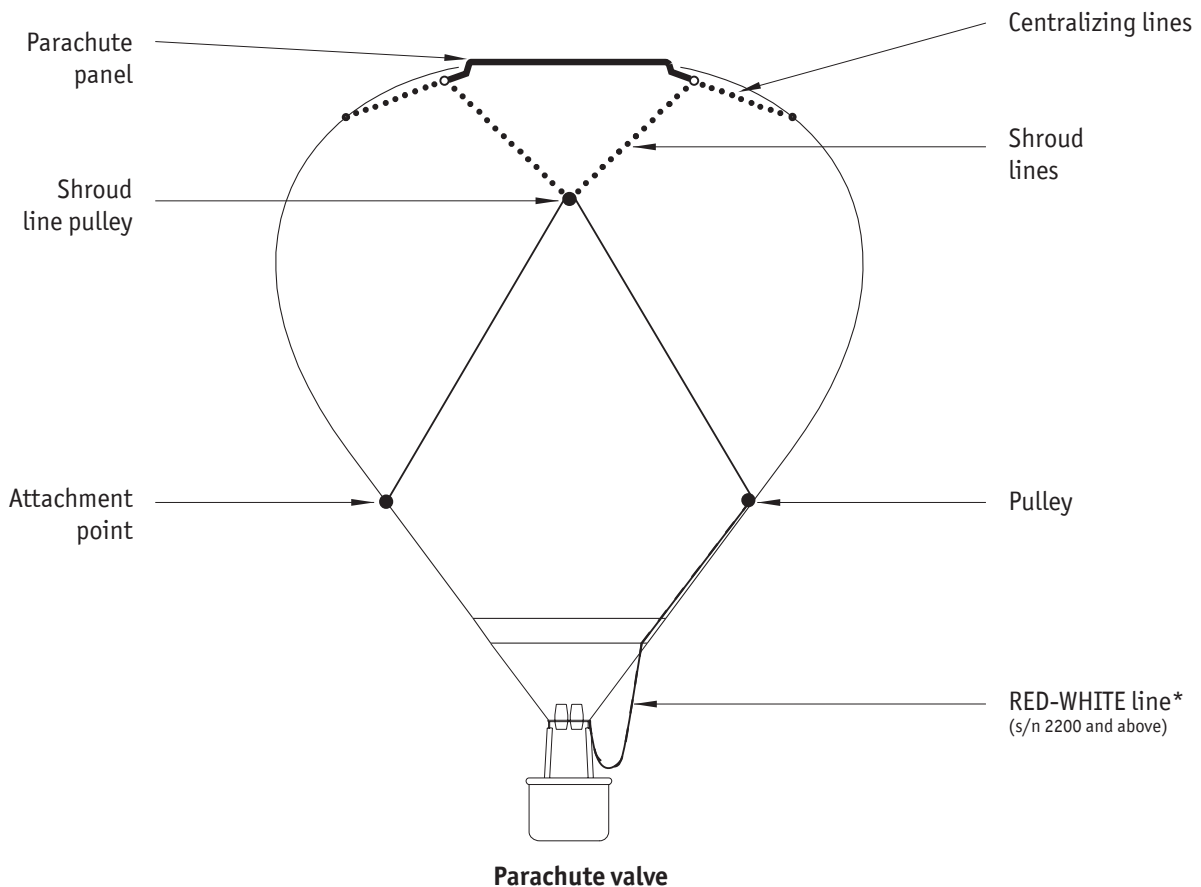

#### Parachute controls:

	Desired action	Control motion required
In-flight venting and deflation	Open parachute	Pull and hold RED-WHITE line *
	Close parachute	Release RED-WHITE line - Parachute closes itself *

\* Up to s/n 2199, the envelope is fitted with red line.

**6.4.2 Paralite**

The Paralite deflation system is very similar to the parachute except the centralizing lines are free to travel in pulleys at the vent aperture edge. At the other ends the centralizing lines are connected together to a weight that provides for an easier resetting of the vent panel.

Two activation lines are fitted. The RED-WHITE line\* is used for venting. When released the Paralite resets itself by internal overpressure and action of the weight. The WHITE line is used only for a proper closing of the vent if necessary.

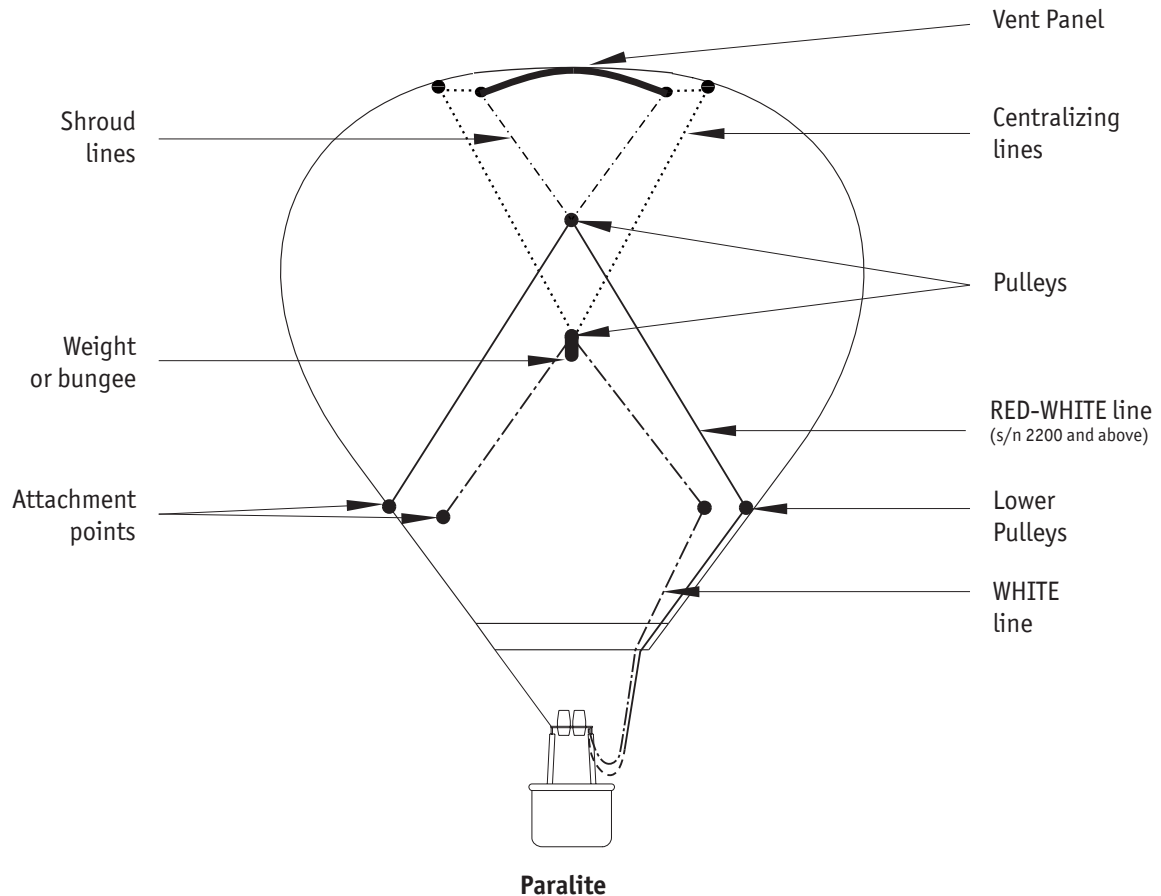

**Paralite controls:**

	Desired action	Control motion required
In-flight venting and deflation	Open paralite	Pull and hold RED-WHITE line *
	Close paralite	Release RED-WHITE line * - Paralite closes itself Pull WHITE line if necessary

\* Up to s/n 2199, the envelope is fitted with red line.

**NOTE** *It is possible to have bungee (elastic rope) instead of a weight attached to the white line. For the system to work, it is necessary to keep the white line taut. Determine the correct length by pulling the white line to the point where the vent panel seals the vent hole. At this length, make a loop on the white line and use a carabiner to secure the taut white line to the basket structure or burner frame. If the vent panel does not seal properly, move the securing loop to make the white line shorter.*

**WARNING** *It is prohibited to set the correct length of the white line during the flight! It must be done prior to take-off. The incorrect setting of white line may lead to Paralite leaks during the flight resulting in uncontrolled descent!*

### 6.4.3 Slide Vent (2 control lines)

The Slide Vent is a fast deflation system capable of two modes of venting. The in-flight venting (Parachute mode) is provided by simply pulling the vent panel down as a Parachute. For an efficient and fast deflation (FD mode) the vent panel can be gathered into the center of the vent aperture creating a big area for the hot air to escape. The Slide mode is not self-sealing. The RED-WHITE line is to be pulled for closing it.

Two activation lines are fitted: RED-WHITE line for in-flight venting and closing the FD mode, and RED line for activating the FD mode.

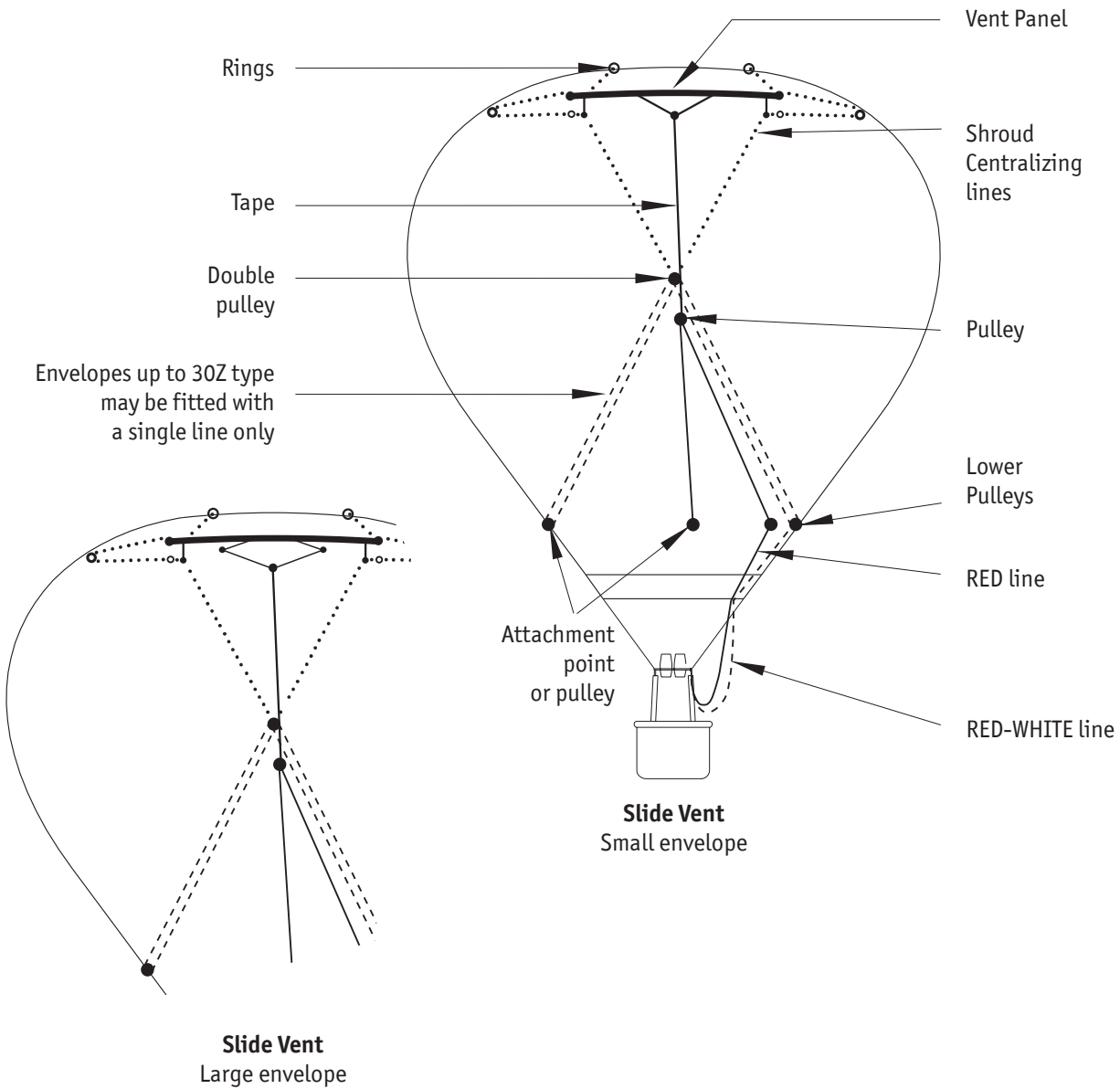

#### Slide Vent controls:

	Desired action	Control motion required
In-flight venting	Open Parachute mode	Pull and hold RED-WHITE line
	Close Parachute mode	Release RED-WHITE line - Parachute closes itself
Deflation	Open FD mode	Pull RED line
	Close FD mode	Pull RED-WHITE line

**6.4.4 Lite Vent, Slide Vent (3 control lines)**

The Lite Vent is a fast deflation system capable of two modes of venting, similar to a Slide Vent, but with a different arrangement of shroud centralizing lines and more efficient in-flight venting.

Three activation lines are fitted: RED-WHITE line for in-flight venting and closing the FD mode, RED line for activating the FD mode, and WHITE line for resetting the FD mode.

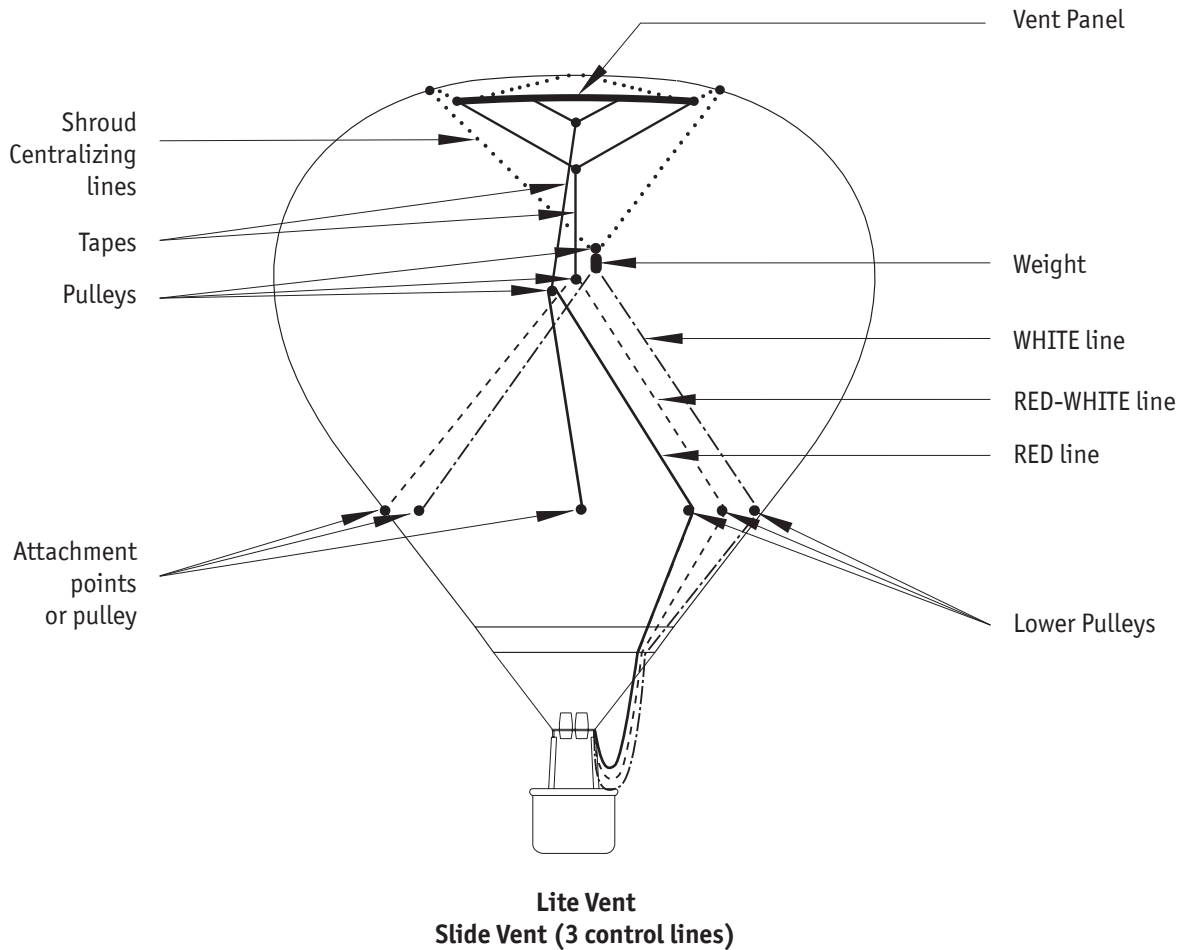

**Lite Vent, Slide Vent (3 control lines):**

	Desired action	Control motion required
In-flight venting	Open Parachute mode	Pull and hold RED-WHITE line
	Close Parachute mode	Release RED-WHITE line - Parachute closes itself
Deflation	Open FD mode	Pull RED line
	Close FD mode	Pull RED-WHITE or WHITE line Pull WHITE line for good seal (if necessary)

## 6.4.5 Smart Vent

The Smart Vent is a fast deflation system capable of two modes of venting, similar to a Slide Vent. The activation lines and their operation is identical as the Slide Vent.

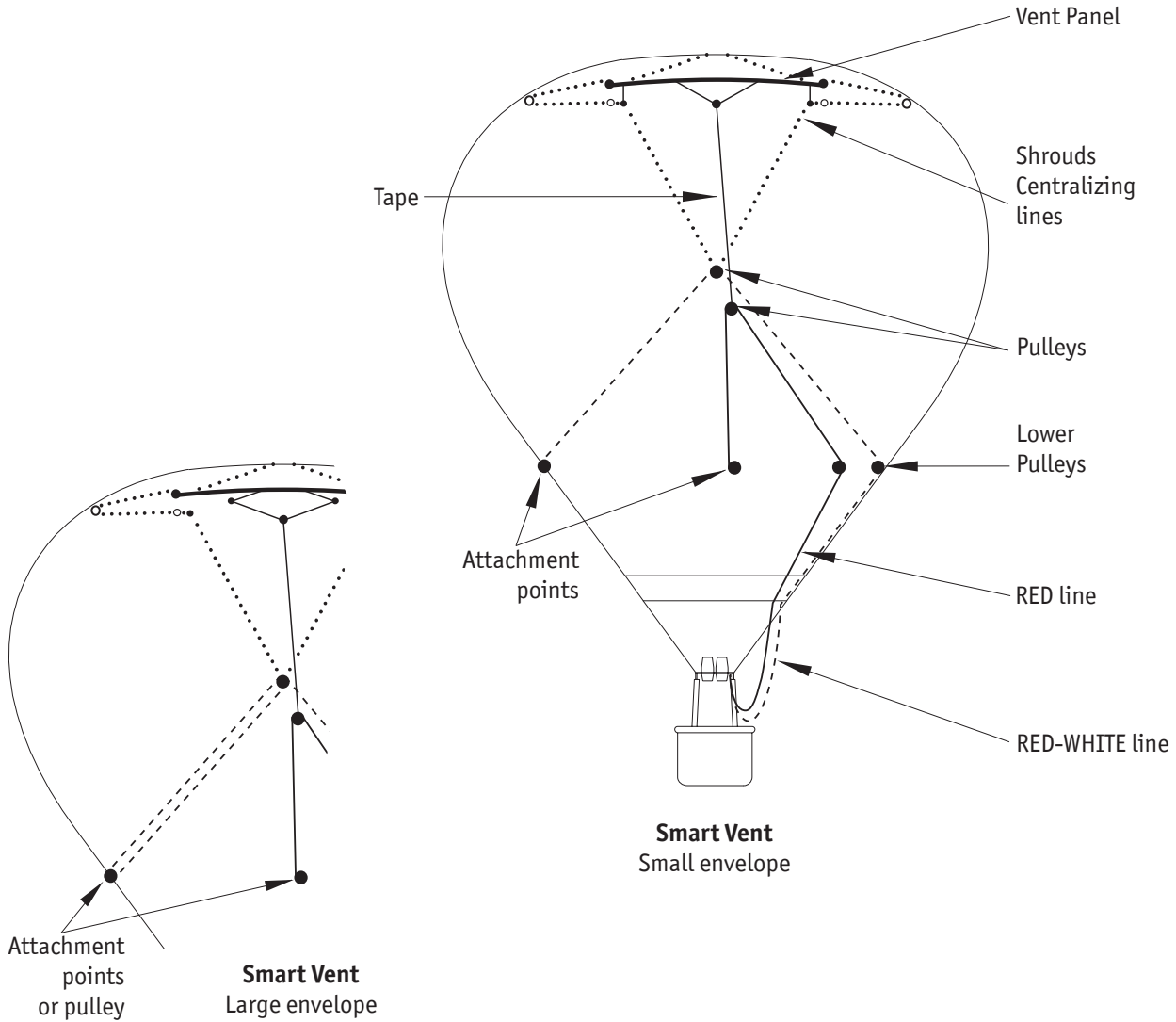

### Smart Vent controls:

	Desired action	Control motion required
In-flight venting	Open Parachute mode	Pull and hold RED-WHITE line
	Close Parachute mode	Release RED-WHITE line - Parachute closes itself
Deflation	Open FD	Pull RED line
	Close FD	Pull RED-WHITE line

### 6.4.6 Rip Panel

A Panel may be used in place of, or in addition to, a conventional deflation system to aid final deflation. Once opened it can not be reset and must never be used in flight.

A Rip Panel is sewn to the envelope along one edge and held in place around the remaining edges by velcro. The panel must be carefully closed before the envelope is inflated. In order to get a good seal each side of the panel must, in turn, be pulled taught from each end as the panel is put in place and sealed firmly throughout its length.

Once the panel is correctly in place the rip lock (or rip locks) must be correctly fitted in accordance with this illustration below. The rip lock is a safety item, a strong pull is required to open it which prevents an unintentional opening of the Rip Panel.

The Rip Panel is opened by pulling on the RED line. A strong pull releases the rip lock, then the Rip Panel opens.

**WARNING** Once opened the Rip Panel can not be closed and **MUST NEVER BE USED IN FLIGHT!**

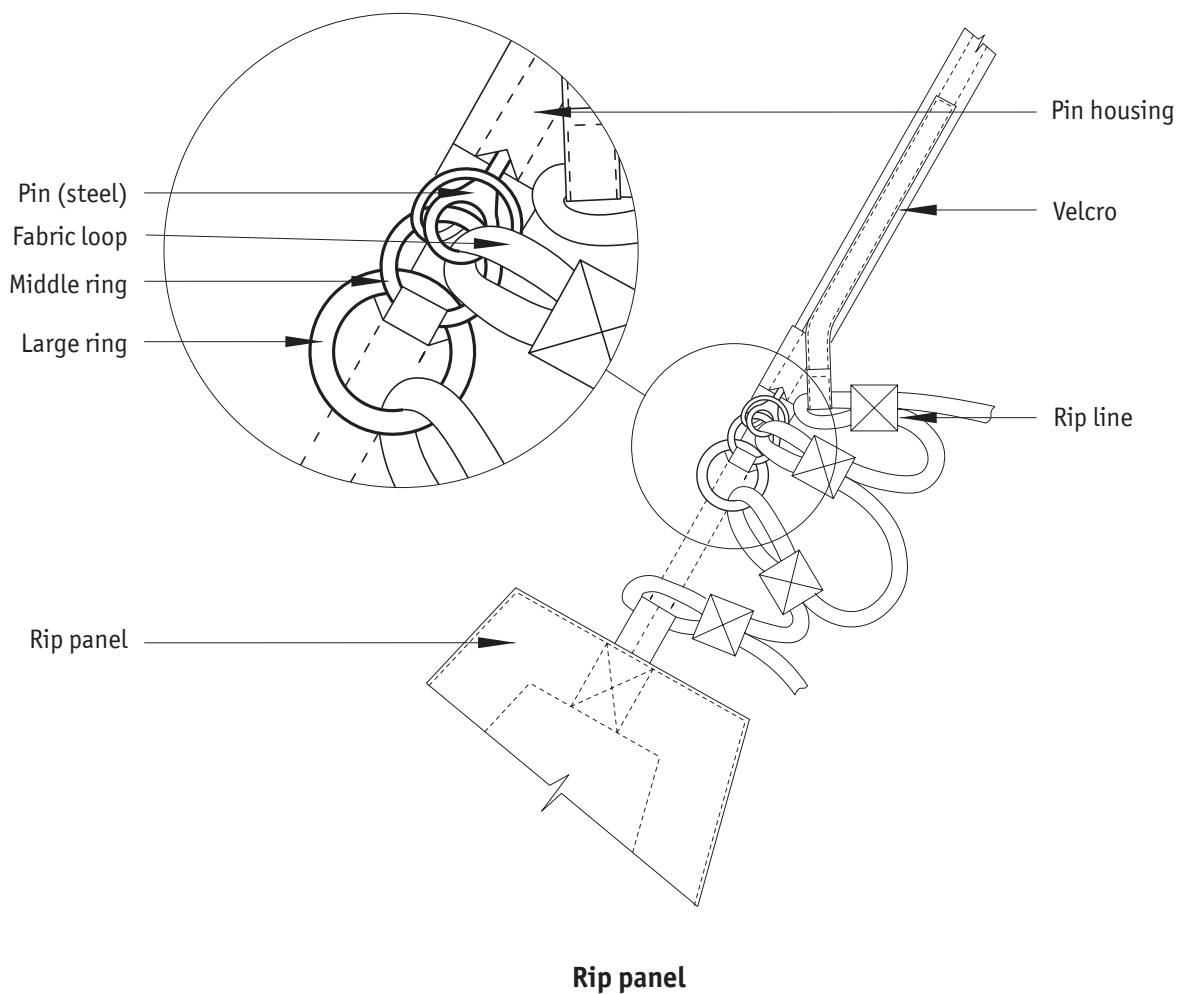

## 6.4.7 Rotation Vents

Rotation Vents may be fitted at the equator of an envelope. These rotation vents, when used in flight, vent air through vertical slits at the equator. These rotate the balloon about its vertical axis which is important for the balloon's correct alignment for landing.

The rotation vents are controlled by two lines: black line turns the balloon to the pilot's left and the green line turns the balloon to the pilot's right.

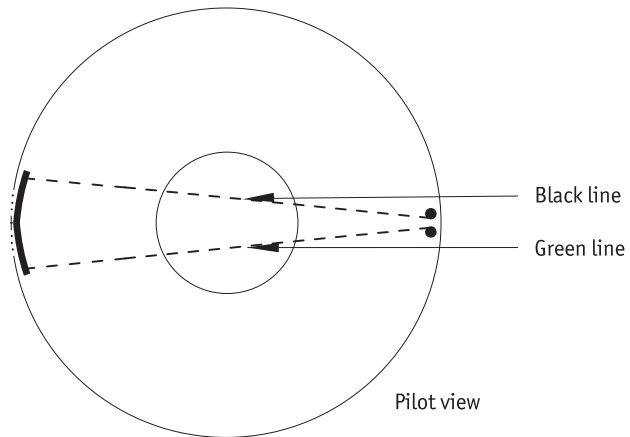

### Another possible control line routing

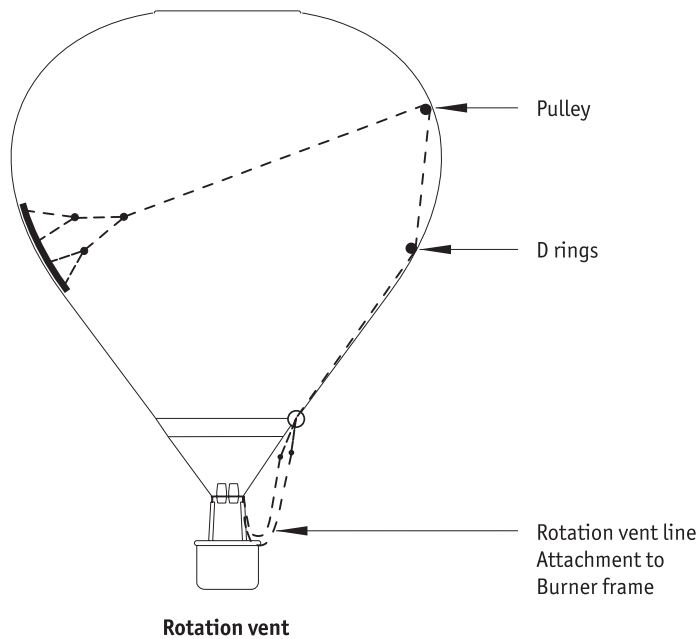
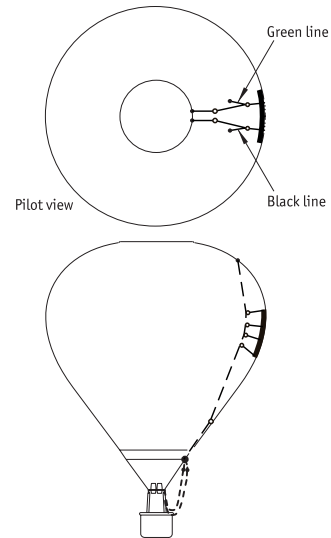

### Line routing when additional RV is fitted

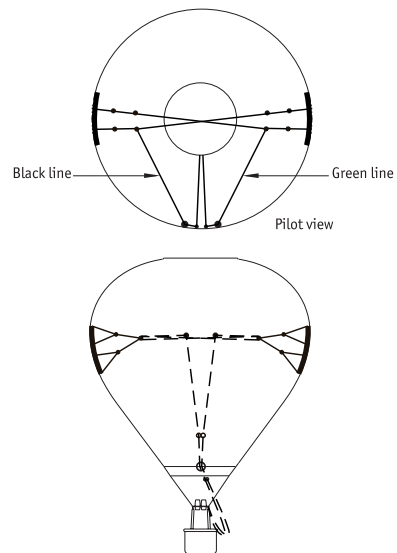

## 6.4.8 Temperature Streamer

A Temperature Streamer is a fabric flag of a contrasting color attached inside the envelope on its top via a melting link. If the envelope is overheated the solder in the melting link melts and the Temperature Streamer falls out of the envelope warning the pilot. The melting link is designed to detach at 124°C (255°F).

**CAUTION** *The fall of the Temperature Streamer need not indicate an immediate danger. The balloon remains controllable but intense maneuvers must be avoided. Heat carefully using only short bursts. Note the altitude in which the Temperature Streamer fell and keep lower for the rest of the flight.*

Once the Temperature Streamer has fallen, the melting link must be changed for a new one (unless an envelope temperature indicator that gives a direct reading is used) and envelope inspection is required when the Tempilabel shows temperature of 138°C (280°F) or higher (see KF Maintenance Manual for details).

For location of Temperature Streamer on your envelope type refer to Appendix 7 of this manual.



### 6.4.9 Tempilabel

A Tempilabel is a small strip sewn inside the envelope with several temperature-sensitive areas changing color permanently according to the temperature reached. This provides a permanent record of the maximum temperature that the envelope has reached.

After overheating of the envelope a new tempilabel is sewn alongside the old one which must remain.

For location of Tempilabel on your envelope type refer to Appendix 7 of this manual.

### 6.4.10 Electronic Thermometer

An electronic thermometer is optional equipment for continuous reading of the temperature inside the envelope. It can be a separate device or part of multipurpose instrument such as Volirium AG, Flytec, DBI, etc. It consists of the reader (showing data to the pilot) and a measuring device fitted with sensor. The reader needs to be secured in the basket to provide pilot an easy access to the data. The measuring device needs to be installed at the designated attachment point on the top of the envelope and its sensor must be attached via designated grommet to a Velcro loop inside the envelope. The sensor must not directly touch the envelope fabric but it needs to be 20 mm (0.8") away from the envelope surface - the Velcro loop is designed to keep the correct distance (there is a „spacer seam“ in the correct distance, place the sensors as close to it as possible and seal the loose ends of the Velcro loop).

The sensor is to measure the temperature of the hot air inside the envelope, not the temperature of the fabric.

<b>NOTE</b>	<i>The temperature inside the envelope is several degrees higher than the temperature of the fabric, so this does not increase the risk of overheating the fabric. In case the Temperature Streamer falls off, refer to the temperature recorded on the Tempilabel.</i>
-------------	---

For location of electronic thermometer attachment point on your envelope type refer to Appendix 7 of this manual.

## 6.5 Burner

The burner is the heat source of the balloon and an efficient means for controlling the vertical profile of the flight. It consists of one or more burner units and a burner frame. Within the burner, liquid gas is vaporized and burnt to heat the air within the envelope. The gas is ignited by a pilot light that runs all the time that the balloon is inflated. Both the main burner and whisper burner have an "off" or "on" mode. The amount of heat is controlled by duration of the heating and number of burner units engaged. All burners are controlled by means of the valves placed on the underside of the burner on the manifold block.

The heat of the burner is greatly influenced by the fuel pressure that is affected by the ambient temperature. In lower temperatures pressurization of the fuel cylinders is recommended.

<b>CAUTION</b>	<i>Burner malfunction due to oxygen insufficiency in the ambient air may appear in altitudes above 6 000m (20 000 ft) AMSL.</i>
----------------	---

### 6.5.1 Main Burner

The high output Main Burner is fed with liquid propane which passes through a vaporizing coil prior to combustion. Fuel flow is controlled by an on/off valve called the Main Blast Valve (MBV).

Ignis Plus burner unit can be equipped with the MBV lever lock function for long continuous heating (the lock keeps it in open position).

The MBV is closed when the lever is in the position shown in Fig.1 (the lever is in the default position) and it is open when lever is in the position shown in Fig.2 (the lever is pressed to burner handle). The MBV is open and locked if it is in the position shown in Fig.3 (lever is pressed against the burner handle and rotated around the axis of the unit into the cutout in the burner handle end cap).

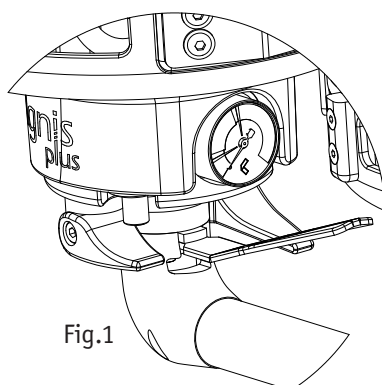

Fig.1

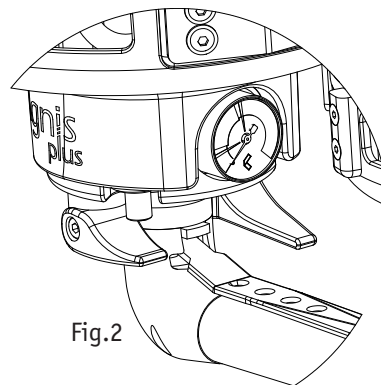

Fig.2

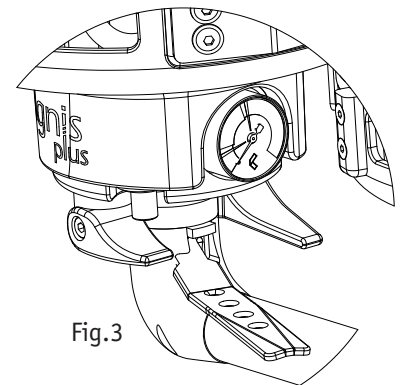

Fig.3

## 6.5.2 Whisper Burner

A whisper burner (AKA Liquid Fire or Cow burner) is fitted to each burner unit. The whisper burner feeds liquid fuel directly to a multi hole jet without passing through the vaporizing coil. This provides a quieter but less powerful flame. It is intended for use when reduction of burner noise is desired.

The whisper burner is closed when the lever is in position as shown in Fig. 1 (the default position) and opened when the lever is in position shown in Fig. 2.

**WARNING** *The whisper burner remains OPEN when the lever is flipped over as shown in Fig. 3. and Fig. 4. Keeping lever at those positions is not allowed as it can be potentially dangerous.*

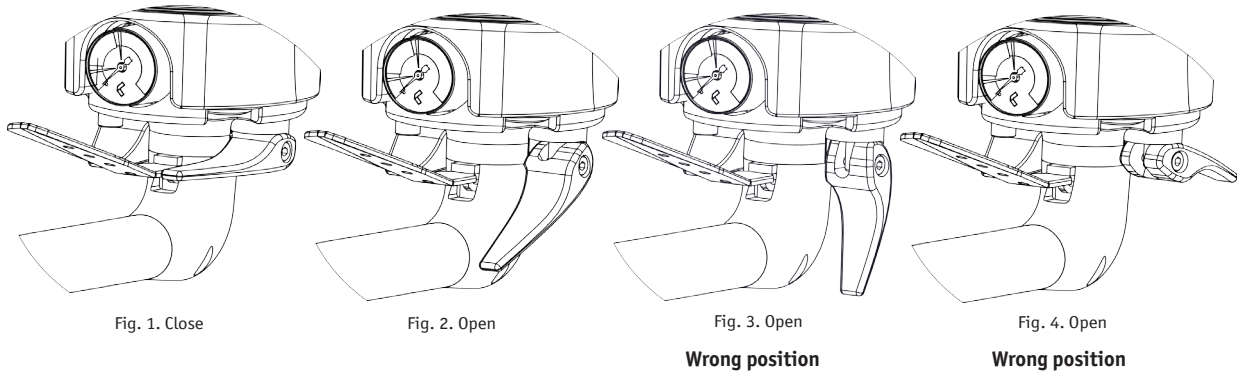

## 6.5.3 Pilot Light

Burner ignition is provided by a pilot light. A pilot light is fueled either by liquid propane taken from the burner block and vaporized in the vaporizer or from vapor taken by a separate hose from the fuel cylinder. Each pilot light has its own piezo igniter which is covered by the handle of the pilot light lever, when it is in the off position. To run the pilot light, open the valve and ignite the vapor using the piezo igniter. To turn the pilot light off move the pilot light lever to the closed position.

The piezo igniter is activated by pressing on the piezo button. Pressing the button causes a spark between the upper point of the igniter and the pilot light cup and ignites the pilot light.

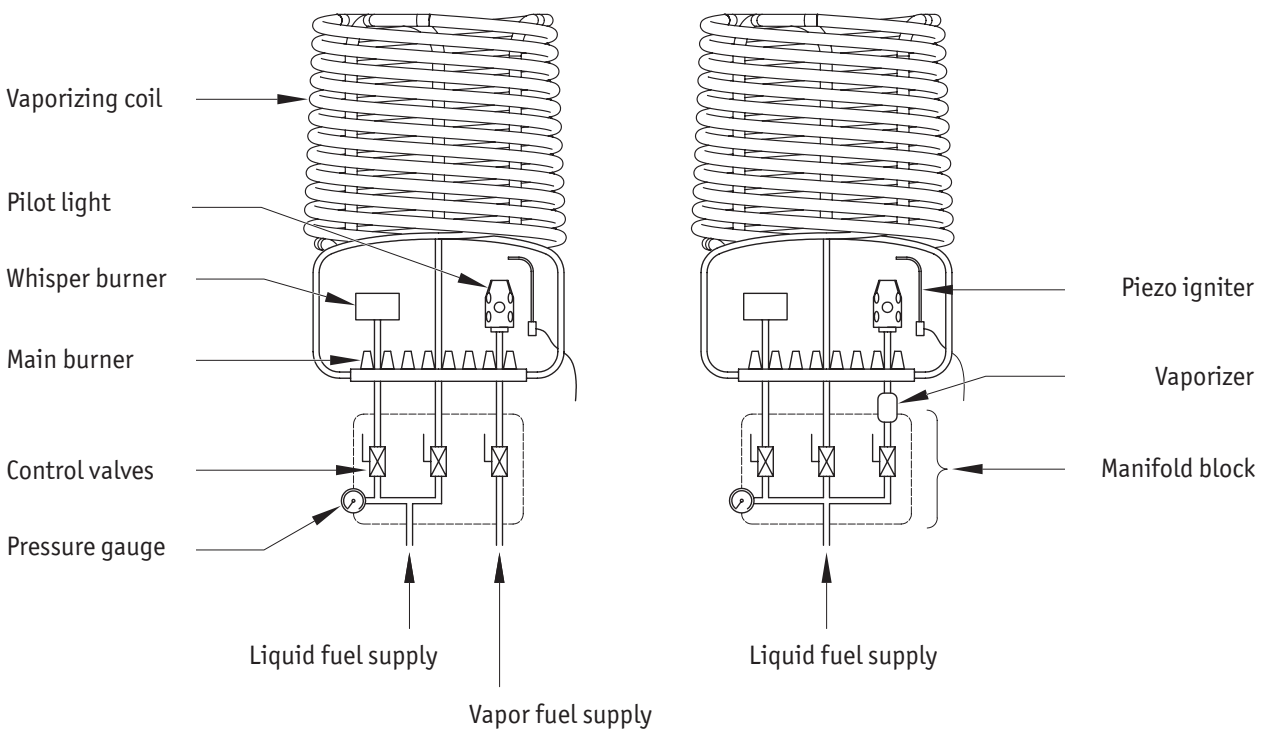

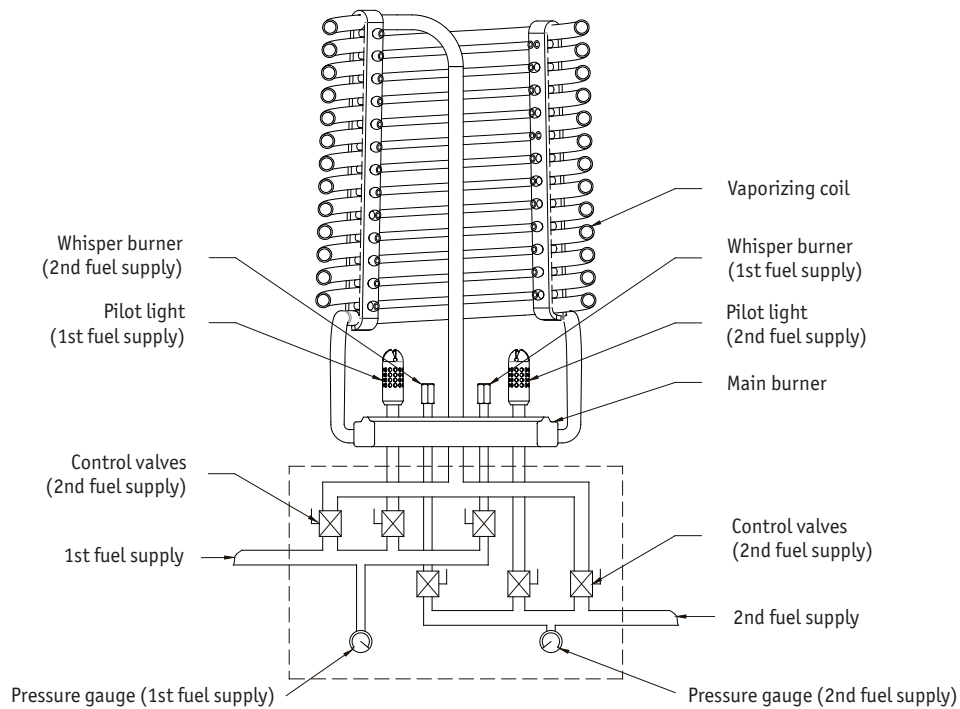

#### 6.5.4 Pressure Gauge

A Pressure Gauge is fitted to each burner unit. This gauge shows the pressure of the liquid gas in the fuel system.

#### 6.5.6 Fuel Supplies

In double, triple or quad burners each burner unit has its own independent fuel supply. In case of a single burner two independent fuel supplies must be connected, one to each liquid fuel hose.

The liquid fuel hoses are identified by matching colored bands at each end of a hose. Fuel should always be vented from fuel hoses when the burner is not in use. The remaining fuel can cause damage to the fuel hoses due to heat expansion.

#### 6.5.7 Burner Frame

The burner frame is made from stainless steel tubing. The burner units are swivel-mounted on a gimbal block on a horizontal bar that runs across the burner frame (this provides a two-axis gimbaled system). At each corner the burner frame has lugs, where the basket carabiners hook up. The tube sockets are either swinging or fixed. The nylon rods that support the burner above the basket are fitted into these sockets.

#### 6.5.8 Adjustable Burner Frame

A variable height burner frame allows the burner to be raised and lowered relative to the basket floor. This adjustment can safely be carried out in flight.

#### 6.5.9 Ignis Gyro

The self-centering burner, Ignis Gyro, is composed of 2, 3 or 4 burner units. Instead of a standard gimbal a universal joint with a compression spring is used. This enables for a simple inclination of the burner and its automatic return into vertical position when releasing the burner handle. The operating upright position of the burner is secured by a spring-loaded pin. When releasing this pin the entire assembly can be tilted aside for transportation.

## 6.5.10 Ignis Burner

The Ignis burner is available as a double, triple or quad burner.

The main burners are fitted with blast valves that are operated by squeezing the control lever towards the hand grip. The blast valve levers are arranged so that pairs of burners may be operated together by using one hand.

The whisper burner is operated by a silver lever that is rotated downwards to open the valve.

The Ignis burner is fitted with either a vapor or liquid pilot light. The red pilot light lever covers the pilot light igniter when it is in the closed position. The pilot light lever is rotated downwards through 180 degrees to open the pilot light flame.

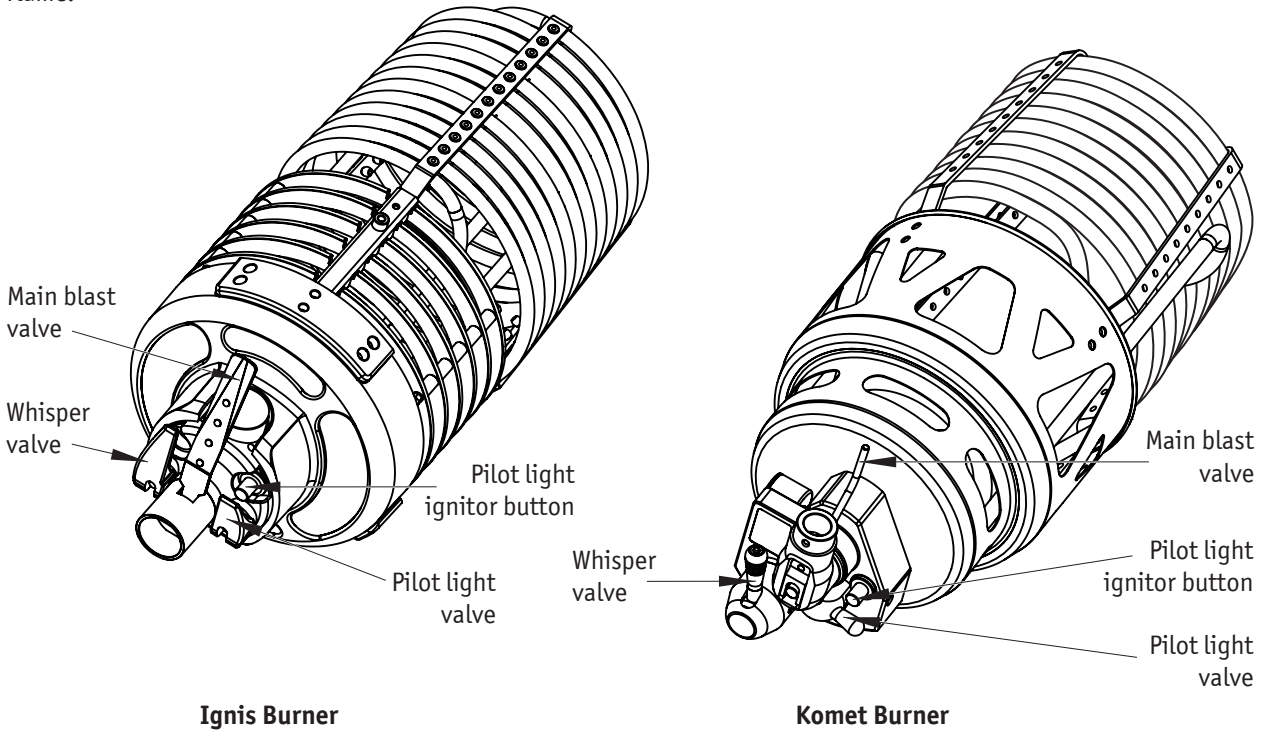

## 6.5.11 Komet Duo and Komet Trio Burners

The Komet Duo burner is produced in two variants:

- Burners up to serial number 104 are fitted with the crossflow valve and smaller vaporizing coil.
- Burners of serial number 105 and higher don't have the crossflow valve. The vaporizing coil is greater for higher heat output. Modified controls enable the pilot to operate both burner units with only one hand. Burners of these serial numbers were also assembled in Komet Trio (triple) version.

Komet burners are fed by two hoses of vapor and liquid phase. The amount of pilot flame is regulated by the valve on the fuel cylinder.

<b>NOTE</b>	<i>Burners Komet Duo up to serial number 104 are fitted with crossflow valve. With the crossflow valve open the fuel is supplied from one fuel cylinder when both main blast valves are operated at the same time.</i>
-------------	--

## 6.5.12 Sirius Burner

The Sirius burner is a single unit burner with all the features of a double. The main burner is fitted with two independent main blast valves that are operated by squeezing a control lever towards a hand grip. Each main blast valve controls fuel flow from one independent fuel source. The blast valve levers are arranged so that they may be operated together with the whisper burner levers by using one hand - one hand is operating a main blast valve fed by one fuel source and whisper burner valve fed by another fuel source at the same time. That offers better performance of the burner unit, because each burner is fed from independent fuel source and therefore can use maximum of the fuel pressure. The whisper burner is operated by a red or green lever (color is matching the color mark on the corresponding fuel hose) that is rotated downwards to open the valve. The Sirius burner is fitted with two liquid pilot lights. The red

or green pilot light lever (color is matching the color mark on the corresponding fuel hose) covers the pilot light piezo igniter when it is in the closed position. The pilot light lever is rotated downwards through 120 degrees to open the pilot light flame.

**NOTE** Do not open both the main blast valves at the same time, as the power cannot be increased this way.

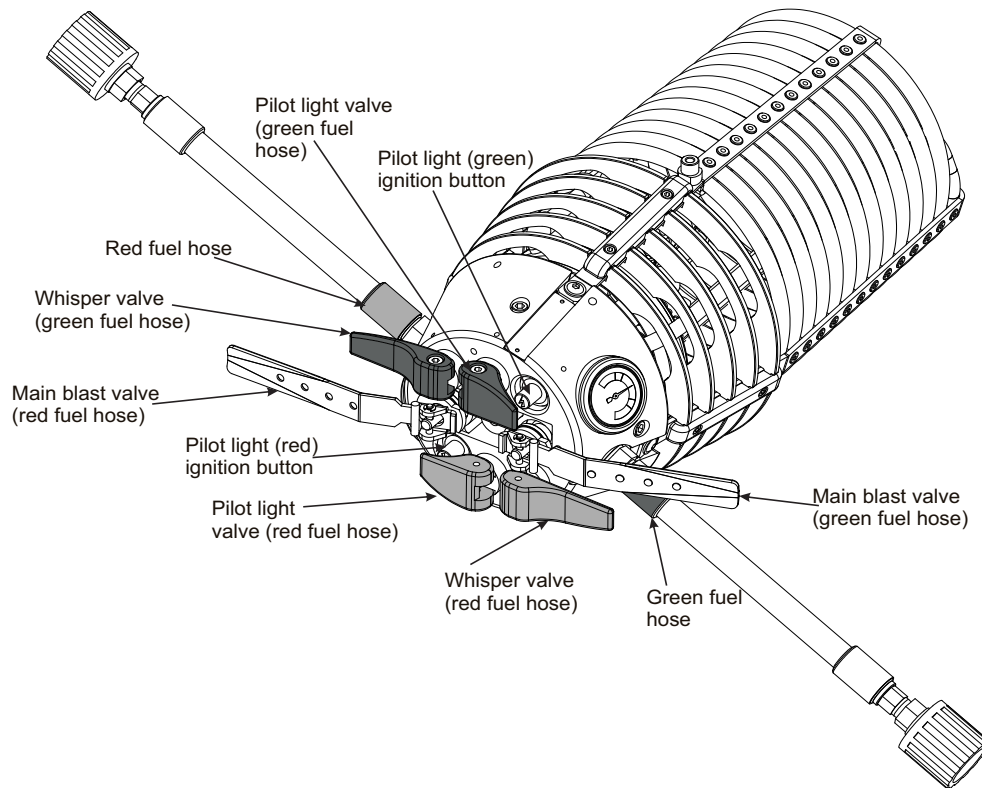

The outer dimensions, positions of the support rods' sockets and the carabiners' attachment points of the BASIC and SIRIUS burner frame are the same, therefore the BASIC and SIRIUS burner frames are interchangeable. SIRIUS burner frame allows adjustment of the stiffness (resistance of the frame during movement of the burner unit). This can be done using two screws at the ends of one of the suspensions holding the burner unit (one screw is for front-back movement, another for right-left movement). Turning the screw(s) increases/decreases the stiffness of the frame. This adjustment can also be made in flight.

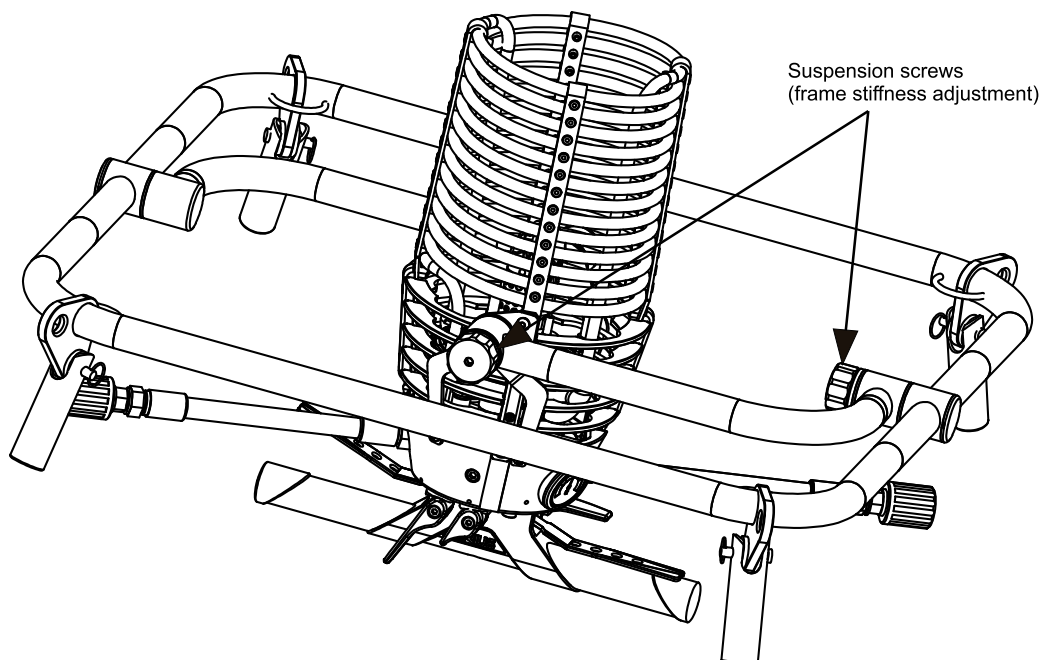

## 6.6 Fuel Cylinder

### 6.6.1 General

Propane is carried in liquid form under pressure in cylinders. These cylinders are either „Standard“, supplying liquid fuel feed only, or „Master“ with an additional pressure regulated vapor supply to feed pilot lights.

Liquid fuel is drawn from the bottom of the fuel cylinder via an internal dip tube. The supply is controlled by an external valve with either a quick shut off lever or a hand wheel. Both the types can be fitted with either a Rego type screw connection or a Tema push-on connector.

On Master cylinders a regulated vapor pilot flame supply is taken direct from the top of the cylinder through a hand wheel valve and a suitable regulator. The vapor hose is connected by using a quick release coupling.

Each fuel cylinder is fitted with a contents gauge which registers the last 35-40% of the content of the cylinder. Each fuel cylinder is fitted with a maxfill tube connected to a screw valve. This valve is opened for refueling and when the escaping vapor fuel gives way to liquid fuel it indicates the cylinder is full.

Each fuel cylinder is equipped with a pressure relief valve (PRV) which protects the cylinder against excessive internal pressure.

All cylinders must be fitted with a padded cylinder cover to protect both the cylinder from damage in transit and the persons in the basket from injury on landing.

<b>NOTE</b>	<i>Fuel cylinders that are approved for use in Kubiček balloons are listed in section 8 and the Equipment List and Appendices of this Manual.</i>
-------------	---

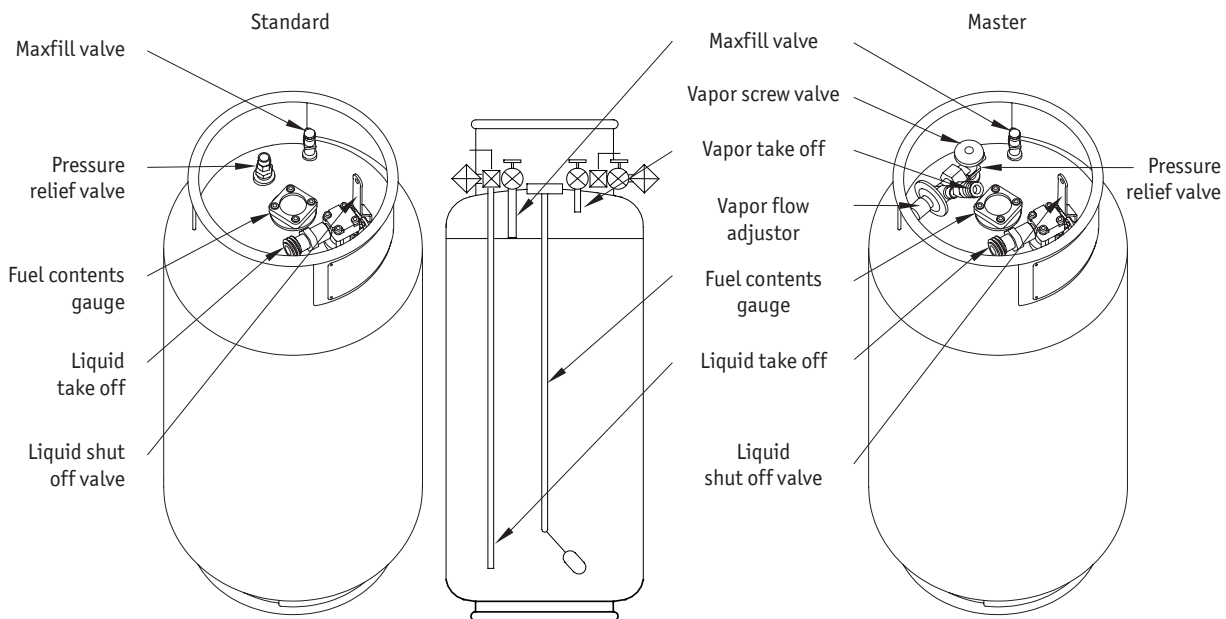

## 6.7 Baskets

Baskets are made with traditional wickerwork sides above a solid marine ply floor. Load-bearing basket cables form a continuous sling around the basket and are connected at both ends to the burner frame. These cables support the weight of the basket when the balloon is in flight.

Flexible rods fit into sockets on the top rim of the basket and into sockets on the underside of the burner frame to support the weight of the burner. The support rods and the cables that are beside them should be covered by removable padded suede sleeves that also protect the fuel hoses.

The basket walls have small openings to permit straps to be fed through, so that the fuel cylinders can be secured to the inside walls of the basket.

Equipment and instruments that are carried in the balloon may be strapped to the basket or put into padded bags that are secured to the sides of the basket. Light weight flight instruments and radios may be attached to the rod covers by velcro straps. Below the inside rim of the basket there are rope handles for use by passengers during landing.

### 6.7.1 Partitioned Baskets

Larger baskets have internal partitions woven into the walls and fixed to the floor of the basket. These partitions provide greater structural integrity to the basket and separation between groups of passengers. In these baskets the pilot and fuel cylinders are contained in a separate compartment from the passengers.

### 6.7.2 K10S and K13S Baskets

The K10S and K13S baskets have a multilayer basalt-aramid or glass-aramid composite sandwich floor instead of plywood. Composite floor is also available for other open baskets up to K19L as optional. Both upper and lower tube frames are made of aluminum alloy.

### 6.7.3 Pilot Restraint Harness

A pilot restraint harness (if fitted) is designed to secure the pilot inside the basket during landing. The harness consists of the waist belt secured with a seat belt type buckle and a strap of adjustable length with the clips on both ends. One clip is to be fixed to a D ring on the waist belt and the other to the D ring on the basket floor. One more restraint harness (for pilot's assistant) can be fitted to the same D ring on the basket floor as the pilot's restraint harness. The pilot should wear and adjust the waist belt before landing and adjust the strap length during approach. The length of the strap must allow the pilot to reach all controls while preventing him from falling over the basket rim. In emergency the waist belt can be released quickly.

### 6.7.4 Quick Release

A quick release is designed to restrain the balloon during inflation and while the balloon is being prepared for flight. A quick release must be used for each take-off.

A quick release is attached to the envelope carabiners or to the burner frame lugs. The jaw is fixed to a restraining line which is in turn secured to either an anchor point on the ground or to the front of a heavy vehicle. A securing pin or other safety device prevents the release being opened inadvertently.

### 6.7.5 Tethering lugs

If required some baskets can be fitted with tethering lugs located on the steel upper frame. These lugs provide alternative attachment point for a quick release.

### 6.7.6 Basket Door

Basket door is optional equipment for the easy embarking and disembarking of passengers, mainly elderly or disabled persons. The door is to be open/closed only on the pilot's instruction prior to take-off and before the balloon has been released from the quick release and after landing.

The door and its frame structure is made of stainless steel tubes and wickerwork done in the same manner as the standard basket wall. The door is hinged on both sides.

Securing the pins is provided by attaching the pin lugs to the door frame lugs with carabiners.

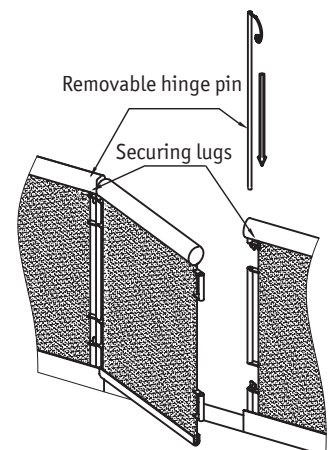

#### **WARNING**

*Door hinge pin(s) or door zippers (for collapsible baskets K10C and K13C) must be secured during the entire flight! The door must be closed during the entire flight!*

## 6.7.7 Passenger Seat

The passenger seat is optional equipment designed for easy installation and removal by the pilot without using tools. The composite seat with upholstery and four-point restraint harness is supported on a stainless steel trestle that attaches to the basket floor by four corner pins and a central bolt.

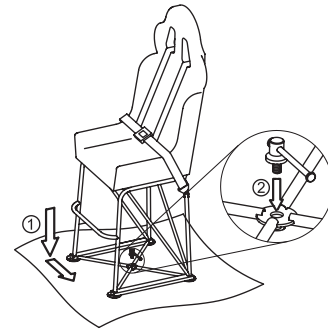

### Seat installation:

1. Insert the pins in the underside of the trestle into the grooves in metal plates on the basket floor and slide the seat sideways to fasten all pins.
2. Screw in the central bolt and tighten by hand.

<b>NOTE</b>	<i>The correct orientation of seats must be taken into account. All seats must be installed so that all seating passengers face the same direction with their backs to the direction of flight before landing, if possible.</i>
-------------	---

### During pre-flight preparation:

The weight and floor area occupancy of the seat is to be taken into account. The actual weight of the complete set is engraved on the trestle.

Floor area occupied by the seat:      0.27 m<sup>2</sup> (2.9 sq. ft)

## 6.7.8 Removable Partitions

A removable partition is an alternative to a classic, fixed, partition. It allows for an easy change of basket inner arrangement by removal or rotation. The structure of the partition is made of stainless steel tubes. Wickerwork is done in the same manner as the standard basket wall. On the sides the partition attaches to the basket structure by a pair of hinges with continuous hinge pins so that the partition is attached along the entire height. Securing the pins is provided by attaching the pin lugs to the basket structure with carabiners. The lower side attaches to the basket floor by bayonet locks.

### Removable partition installation:

1. Insert the partition in a desired place.
2. Slide the partition sideways to correctly insert the floor pins into the locks.
3. Insert the hinge.
4. Secure all hinge pins with securing carabiners.

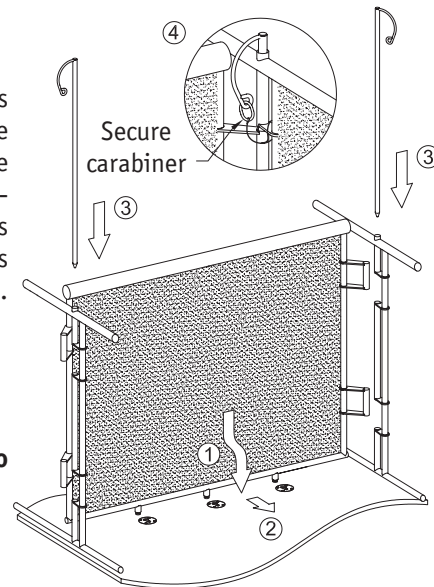

Basket side walls drawn without wickerwork



**Possible configurations**

The possible configurations of baskets are illustrated in the following picture. In any case the minimum required occupant floor area rule as described in Appendix 2 remains effective.

**Possible configurations of the baskets:**

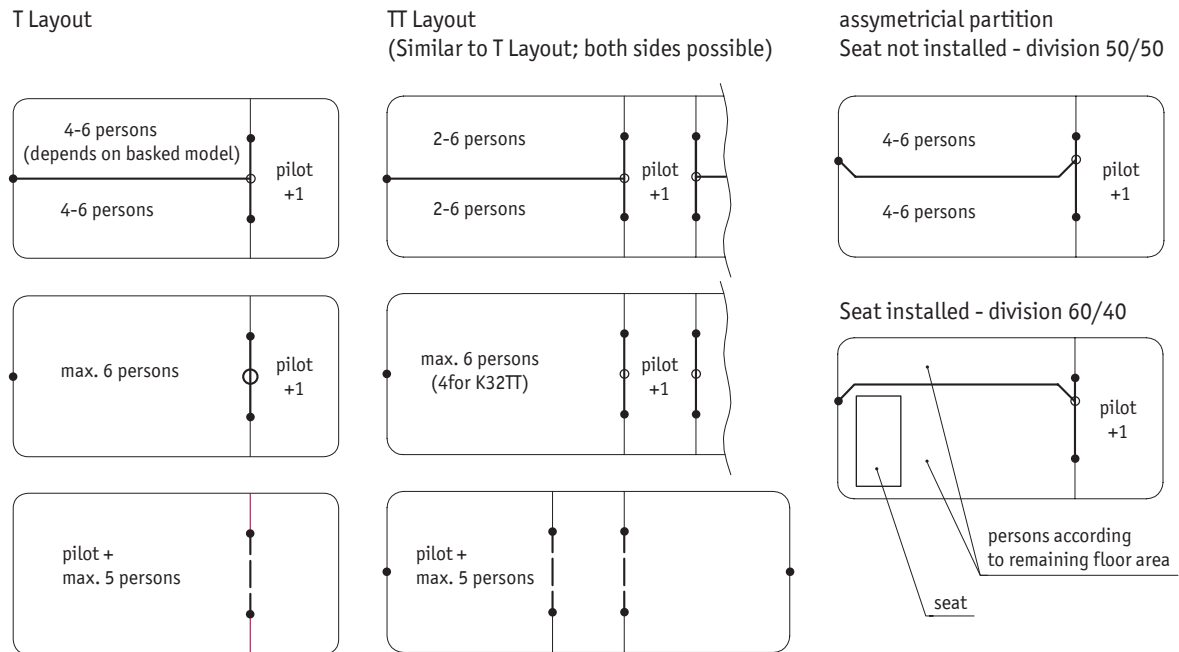

**Baskets K100, K110**

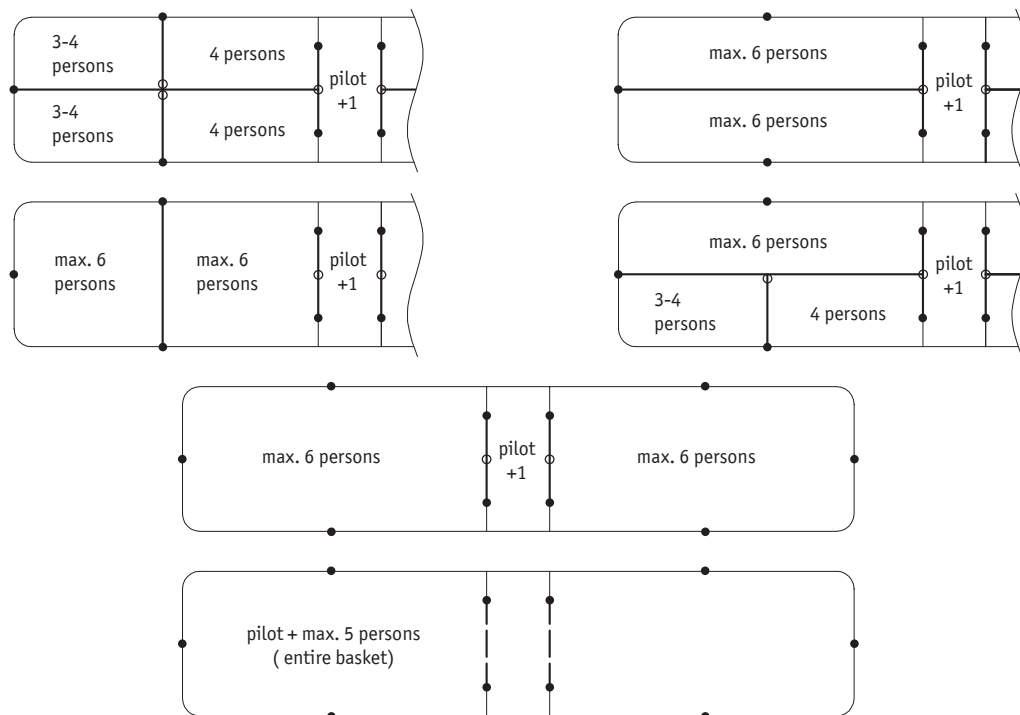

**Legend**

- partition hinge
- partition hinge fitted on removable partition
- basket outer wall or fixed partition
- removable partition
- - - non-woven pilot partition

## Assymetrical partition

In baskets fitted with a passenger seat, a partition with asymmetrical hinges can be used. In normal position such partition divides the space into two equal halves. In the asymmetrical arrangement (partition rotated) the compartment behind the seat is narrower by 13.5 cm.

Even with an asymmetrical arrangement of a central partition a minimum required floor area for each passenger of 0.25 m<sup>2</sup> must be provided. A simplified practice for passenger compartment occupancy is:

compartments for 2-5 persons:	narrow compartment occupancy = symmetrical compartment occupancy - 1 person
compartments for 6 persons:	4 persons

### 6.7.9 Non-woven Pilot Partition

If required a classical pilot compartment partition can be substituted by a non-woven one. This type partition is a hollow frame without wickerwork which allows the pilot go through to other parts of the basket. This element is not considered a true "partition" dividing the basket inner space and cannot be used for attachment of fuel cylinders.

**WARNING**

*No operation with the pilot compartment partition removed is allowed.*

## 6.8 Instruments

The instruments used in a balloon are an altimeter (for height measurement), a variometer (to show the balloon's rate of climb or descent), and an envelope temperature gauge (to show the envelope's actual internal temperature or overheating).

## 6.9 Other Equipment

### 6.9.1 Drop Line

The drop line may be used by ground crew to manoeuvre the balloon in light wind conditions. When not in use the drop line is rolled up in a fabric bag, and secured inside the basket.

### 6.9.2 Fire Extinguisher and Fire Blanket

These items are contained within padded bags in the basket and must always be carried in the basket for use in an emergency.

## SECTION 7 - BALLOON HANDLING, CARE AND MAINTENANCE

### 7.1 Introduction

This section contains the manufacturer's recommended procedures for ground handling and servicing of the balloon. It also identifies certain inspection and maintenance requirements which must be followed, if the balloon is to retain that new-balloon performance and dependability.

### 7.2 Inspection Periods

In order to maintain continued airworthiness the following inspections must be made at the appropriate times. Any inspection required by the country in which the balloon is registered and operated must also be completed. Details of inspections, procedures and the licensing requirements of those people who may carry out inspections is contained in the Maintenance Manual for a specific balloon.

A summary of inspections prescribed by the manufacturer is:

Inspection Type	Operating Period	Inspect
Annual inspection	100 flight hours or 12 calendar months, whichever is the sooner	Balloon envelope, basket, burner, fuel cylinders, instruments, equipment and accessories
Ten yearly inspection	Ten years*	Fuel cylinders (see the Maintenance Manual)

\* Determination of inspection dates is based on the date of production, or date of inspection, if any marked on each cylinder.

### 7.3 Balloon Maintenance, Repairs and Alterations

All balloon maintenance and repairs must be carried out in accordance with to the Kubíček Factory Maintenance Manual. If in doubt, contact KF (see the last page of this Manual).

The Maintenance Manual is available for downloading on the Kubíček Factory website: [www.kubicekballoons.com](http://www.kubicekballoons.com).

### 7.4 Ground Handling and Road Transport

After a flight is completed, pack the envelope and transport it in the original envelope bag. If the envelope is damp or wet it must be unpacked and dried as soon as possible. Storage when wet can cause severe damage to the envelope and especially to its artwork (print recessing etc).

Always Vent the burner hoses. Check that the fuel cylinder valves are closed and burner hoses are disconnected from the fuel cylinders.

If the basket is to be winched lengthways onto a vehicle or trailer only approved basket towing loop should be used. The winch cable must not be attached to the rope handles or any other part of the basket.

Applicable for collapsible baskets K10C and K13C only - the baskets can be transported on a vehicle or trailer in folded or non-folded configuration. When folded, the sockets of upper frame have to be in the sockets of the lower frame of the basket. The non-folded configuration means steps secured by velcros, rods locked with pins and cylinder harnesses tightened.

Burners with liquid pilot flames should be transported and stored with the coils uppermost. This will prevent any oil residue in the vaporizer units running into and blocking the pilot flame jets.

When in transit secure the various components of the balloon to eliminate the possibility of damage.

Fuel cylinders should be transported in a vertical position with the valves uppermost and in accordance with the procedures recommended by your national regulatory authority for the transport of liquefied gas tanks.

#### **WARNING**

*Never store or transport a burner with any portion of gas in the fuel hoses.*

## 7.5 Cleaning and Care

### 7.5.1 Envelope

Soiled areas should be cleaned by using a damp cloth. Mild detergents diluted with water may also be used. Before packing the envelope should be thoroughly dried.

### 7.5.2 Basket

The basket requires periodic cleaning. The cane and floor should be cleaned with flowing water and a brush, or pressure washed (protect the upper suede rim from getting wet). The basket should be allowed to dry completely before being stored.

Preserve the cane from becoming too dry because it will become brittle. Clean and protect the leather on the basket bottom and suede on the top rim using products for leather and suede care. If there is a suede cover on the upper rim, simply restore it by brushing with a suede shoe-brush.

<b>NOTE</b>	<i>For more details on cleaning and care of K10C and K13C baskets refer to Appendix 8.</i>
-------------	--

### 7.5.3 Passenger Seat

When dirty, the seat upholstery should be cleaned with a car upholstery cleaning agent. Do not soak it with water. For other parts use mild soapy solution. Allow all parts to dry well before storing.

Store the seat in a clean airy dry place.

### 7.5.4 Burner

After each flight clean carbon deposits from the burner. Check that the movable parts on the frame, frame suspension and hose fittings are free of dirt and mud. Clean and lubricate with silicone oil as required.

Check periodically that the burner valves move smoothly. Lubricate the valves as described in the Kubíček Factory Maintenance Manual, if they are becoming stiff.

### 7.5.5 Fuel Cylinders

Check that the control valves move smoothly and that the pressure regulator is correctly adjusted. Consult your KB approved repair station, if there is any suspicion that they are not working properly or if there is damage to the body of the cylinder.

Lubricate O' ring seals, when required. Keep the areas around the valves and end connectors clean.

### 7.5.6 Instruments

Follow the respective manual for the instrument.

## 7.6 Storage

The balloon must be stored in a clean dry airy place with the envelope in its bag, if possible on a pallet.

The envelope should not be stored damp or wet for more than a few days because residual moisture can result in fabric deterioration due to mold or mildew. A wet envelope should be gently dried by keeping it cold inflated with a fan turning it over as necessary. hot inflating a wet envelope may damage the fabric. Do not expose the envelope to direct sunshine or direct heat when drying.

Store the basket on a pallet so that it is clear of the ground. Water soaking into the wicker and hide of the basket will cause it to deteriorate, so always remove mud from the basket and make sure that it stays dry.

Cylinders should be stored in vertical position, with their valves uppermost in a well ventilated area with no source of ignition or excessive heat.

Burner hoses and T-manifolds must be vented of all fuel as trapped fuel will expand and may cause damage to the hose. While packing the burner the hoses should be rolled on the frame so that there will be no sharp bend on the hose. Special caution should be taken not to kink the hose next to the output fitting. Fuel hoses may never be bent sharply, the smallest bend radius allowed is 90 mm (3 1/2"). A template is provided in Appendix 5.

<b>CAUTION</b>	<i>Fuel cylinders that have been pressurized with nitrogen, but not used at once, should be vented at least for 5 minutes.</i>
----------------	--

## 7.7. Maintenance and Repairs Carried Out by the Pilot

Maintenance and repairs, that may be carried out by a licenced balloon pilot, are those procedures marked as „category A“ in the Maintenance Manual (see Sec. 1.3 of the Maintenance Manual).

## SECTION 8 - EQUIPMENT LIST

This section lists the major components.

### 8.1 Table of Envelopes

Model	Volume		Gores, Envelope Design
	[m3]	[cu ft]	[pcs]
BB9	900	31 800	8, horizontal cut
BB9E	900	31 800	8, horizontal cut
BB9EF	900	31 800	12, horizontal cut
BB12	1 200	42 700	8, horizontal cut
BB12E	1 200	42 700	8, horizontal cut
BB12EF	1 200	42 700	12, horizontal cut
BB14XR	1 400	49 400	16, horizontal cut
BB16	1 600	57 000	8, horizontal cut
BB16E	1 600	57 000	8, horizontal cut
BB16EF	1 600	57 000	12, horizontal cut
BB16XR	1 600	57 000	16, horizontal cut
BB17GP	1 700	59 900	16, horizontal cut
BB17XR	1 700	59 900	16, horizontal cut
BB18E	1 800	64 100	12, horizontal cut
BB18XR	1 800	64 100	16, horizontal cut
BB20	2 000	71 200	12, horizontal cut
BB20ED	2 000	71 200	12, diagonal cut
BB20E	2 000	71 200	12, horizontal cut
BB20GP	2 000	71 200	24, horizontal cut
BB20XR	2 000	71 200	16*, horizontal cut
BB22D	2 200	78 200	24, diagonal cut
BB22ED	2 200	78 200	12, diagonal cut
BB22E	2 200	78 200	12, horizontal cut
BB22	2 200	78 300	12, horizontal cut
BB22N	2 200	78 300	24, vertical cut
BB22Z	2 200	78 300	24, horizontal cut
BB22XR	2 200	78 300	24, horizontal cut
BB22M	2 200	78 300	12, horizontal cut
BB26D	2 600	92 500	24, diagonal cut
BB26ED	2 600	92 500	12, diagonal cut
BB26E	2 600	92 500	12, horizontal cut
BB26	2 600	92 500	12, horizontal cut
BB26N	2 600	92 500	24, vertical cut
BB26Z	2 600	92 500	24, horizontal cut
BB26XR	2 600	92 500	24, horizontal cut
BB26M	2 600	92 500	12, horizontal cut
BB30D	3 000	106 800	24, diagonal cut
BB30E	3 000	106 800	12, horizontal cut

\*20 gores up to and including S/N 2160

# KUBICEK

Model	Volume		Gores, Envelope Design
	[m3]	[cu ft]	[pcs]
BB30ED	3 000	106 800	12, diagonal cut
BB30N	3 000	106 800	24, vertical cut
BB30Z	3 000	106 800	24, horizontal cut
BB30XR	3 000	106 800	24, horizontal cut
BB30M	3 000	106 800	12, horizontal cut
BB34D	3 400	121 000	24, diagonal cut
BB34E	3 400	121 000	12, horizontal cut
BB34ED	3 400	121 000	12, diagonal cut
BB34Z	3 400	121 000	24, horizontal cut
BB37D	3 700	131 700	24, diagonal cut
BB37N	3 700	131 700	24, vertical cut
BB37Z	3 700	131 700	24, horizontal cut
BB40D	4 000	142 400	24, diagonal cut
BB40Z	4 000	142 400	24, horizontal cut
BB42D	4 250	151 300	24, diagonal cut
BB42Z	4 250	151 300	24, horizontal cut
BB45D	4 500	160 200	24, diagonal cut
BB45N	4 500	160 200	24, vertical cut
BB45Z	4 500	160 200	24, horizontal cut
BB51D	5 100	181 500	24, diagonal cut
BB51Z	5 100	181 500	24, horizontal cut
BB60D	6 000	213 600	24, diagonal cut
BB60N	6 000	213 600	32, vertical cut
BB60Z	5 950	209 700	24, horizontal cut
BB64Z	6 400	227 900	24, horizontal cut
BB70D	7 000	249 200	24, diagonal cut
BB70Z	7 000	249 200	24, horizontal cut
BB78Z	7 800	277 600	24, horizontal cut
BB85D	8 500	302 600	28, diagonal cut
BB85Z	8 500	302 600	28, horizontal cut
BB92Z	9 200	327 500	28, horizontal cut
BB100D	10 000	353 100	28, diagonal cut
BB100Z	10 000	353 100	28, horizontal cut
BB105P	10 500	373 700	28, horizontal cut
BB106P	10 600	377 300	28, horizontal cut
BB113P	11 300	402 200	28, horizontal cut
BB120P	12 000	423 800	28, horizontal cut
BB130P	13 000	462 700	28, horizontal cut
BB142P	14 200	500 000	32, horizontal cut
BB150P	15 000	530 000	32, horizontal cut
BB184P	18 400	650 000	32, horizontal cut

<b>NOTE</b>	<i>The actual envelope weight is indicated on the envelope identification plate.</i>
-------------	--

## 8.2 Table of baskets

The below data apply for baskets of s/n 400 and higher. The appropriate data for baskets up to s/n 399 are stated in the Appendix 4 of this Manual.

Basket Model	Basket Description	Applicable Burners Frames	
K7	85 x 85 Open	Fixed or Vario Frame - basic  Fixed frame Sirius	
K10	86 x 116 Open		
K10C	87 x 115 Open, collapsible		
K10S	86 x 116 Open		
K11	98 x 116 Open		
K12, K12A	116 x 116 Open		
K13	116 x 125 Open		
K13C	100 x 125 Open, collapsible		
K13S	100 x 120 Open		
K14	116 x 135 Open		
K15	116 x 135 Open		
K16	116 x 145 Open		
K17	116 x 145 Open		
K18	116 x 155 Open		
K19	116 x 155 Open		
K19L	116 x 162 Open		
K22	125 x 180 Open		
K23	125 x 180 Open		Fixed Frame - K23 type
K25P	125 x 210, two partitions		Fixed Frame - K25P type
K28	160 x 220, T or Y three partitions		Fixed Frame - K32T type
K28H	160 x 235, H four partitions	Fixed Frame - K32T type	
K30PP	125 x 260, three partitions	Fixed Frame - K30PP type	
K32T	160 x 240, T three partitions	Fixed Frame - K32T type	
K32Y	160 x 240, Y three partitions	Fixed Frame - K32T type	
K32TT	160 x 250, double T five partitions	Fixed Frame - K32TT type Fixed Frame - K50TT type	
K40Y	160 x 270, Y three partitions	Fixed Frame - K50 type	
K40T	160 x 270, T three partitions		
K40TTA	160 x 270, double T five partitions		
K50	160 x 300, T or Y three partitions		
K50TT	160 x 300, double T five partitions	Fixed Frame - K32TT type Fixed Frame - K50TT type	
K50TTA	160 x 300, double T five partitions	Fixed Frame - K50TT type	
K50TT8	160 x 300, double T five partitions	Fixed Frame -K60 type Fixed Frame -K60 STRONG type	
K55X	160 x 345, X five partitions	Fixed Frame - K60X type	
K55TTA	160 x 345, double T five partitions	Fixed Frame -K60 type Fixed Frame -K60 STRONG type	
K58HH	160 x 380, double H seven partitions		

# KUBICEK

Basket Model	Basket Description	Applicable Burners Frames
K60X	160 x 390, X five partitions	Fixed Frame - K60X type
K60	160 x 380, double T five partitions	Fixed Frame -K60 type Fixed Frame -K60 STRONG type
K65TTA	160 x 410, double T five partitions	
K70	160 x 440, double T five partitions	
K70TTA	160 x 440, double T five partitions	
K80	160 x 480, double T five partitions	Fixed Frame - K100 type Fixed Frame - K100 STRONG type
K85	160 x 520, (160 x 550 option) double T five partitions	
K90	160 x 520, (160 x 550 option) double double T, nine partitions	
K100	160 x 610, double double T, nine partitions	
K110	160 x 660, double double T, nine partitions	

<b>NOTE</b>	<i>The actual basket weight is indicated on the basket identification plate.</i>
-------------	--

<b>NOTE</b>	<i>Some baskets may be modified to be used with a different burner frame. This information is listed in Form 1 of each modified basket.</i>
-------------	---



### 8.3 Table of Burners

Burner Model	Burner Description	Applicable Burners Frames
SIRIUS	Single burner	Fixed Frame - Sirius
IGNIS - 2 units	Double burner	Fixed Frame - basic
		Vario Frame – basic
		Fixed Frame - K23 type
		Fixed Frame - K25P type
		Fixed Frame - K30PP type
		Fixed Frame - K32T type
		Fixed Frame - K32TT type
		Fixed Frame - K50 type
		Fixed Frame - K50TT type
		IGNIS - 3 units
Fixed Frame - K30PP type		
Fixed Frame - K32T type		
Fixed Frame - K32TT type		
Fixed Frame - K50 type		
Fixed Frame - K50TT type		
Fixed Frame - K60 type		
Fixed Frame - K60X type		
Fixed Frame - K60 STRONG type		
IGNIS - 4 units	Quad burner	Fixed Frame - K32TT type
		Fixed Frame - K50 type
		Fixed Frame - K50TT type
		Fixed Frame - K60 type
		Fixed Frame - K60X type
		Fixed Frame - K60 STRONG type
		Fixed Frame - K100 type
KOMET DUO	Double burner	Fixed Frame - basic
		Vario Frame – basic
		Fixed Frame - K25P type
KOMET TRIO	Triple burner	Fixed Frame - K25P/K32T type
		Fixed Frame - K40Y type

**NOTE** The actual weight of a particular burner (with a frame and hoses) is indicated on the burner assembly.

**NOTE** The outer dimensions, positions of the support rods' sockets and the carabiners' attachment points of the BASIC and SIRIUS burner frame is the same, therefore the BASIC and SIRIUS burner frames are interchangeable.  
Before changing any combination, always check all applicable limitations!

## 8.4 Table of Fuel Cylinders

Manufacturer	Material	Type	Weight			
			Empty		Full	
			[kg]	[lb]	[kg]	[lb]
Kubíček Factory	Duplex stainless steel	KB72L	20	44	50 (propane)	110 (propane)
					54 (LPG)	119 (LPG)
		KB85L	22	48,5	58 (propane)	128 (propane)
					62 (LPG)	137 (LPG)
		KB97L	24	53	65 (propane)	143 (propane)
					70 (LPG)	154 (LPG)
Schroeder Fire Balloons	Stainless steel	VA 50	15	33	36	80
		VA 70	18	40	48	107
Cameron Balloons	Aluminium	Worthington (CB250)	14	31	34	75
		CB2990 *	13	26	34	71
	Stainless steel	CB497	16	35	34	75
		CB599	20	44	41	90
		CB2088	22	48	50	110
		CB426	22	48	51	112
		CB 959	25	55	61	135
		A0/V30	20	44	48	106
		A0/V40	25	55	60	133
	Titanium	CB2385	11	24	34	75
		CB2387	14	31	41	90
		CB2380	13	29	42	93
		CB2383	15	33	52	114
	Duplex stainless steel	CB2900	21	46	44	96
		CB2901	23	51	53	117
		CB2902	24	53	51	113
CB2903		27	60	63	139	
Lindstrand Balloons	Stainless steel	V20	14	31	34	75
		V30	18	40	48	106
		V40	20	44	60	132
	Titanium	T30	10	22	40	88
Thunder & Colt	Stainless steel	V20	14	31	34	75
		V30	18	40	48	106
		V40	20	44	60	132

\* It is strictly prohibited to use any of fuel cylinders Part Number CB2990 Issue A (Alugas) having serial numbers OC25001 to OC25202 and QI14001 to QI14496 in Kubíček balloons.

Manufacturer	Material	Type	Weight			
			Empty		Full	
			[kg]	[lb]	[kg]	[lb]
Ultramagic	Duplex stainless steel	M-20, M-20D	15	33	35	77
		M-30, M-30D	20	44	50	110
		M-40, M-40D	24	53	64	141
Kavanagh	Stainless steel	Mytton 55L	21	46	43	95
		Kavanagh 60	21	46	46	101.5
		Kavanagh 76	23	51	53.5	118
		Kavanagh 82	24	53	57	125.5

Fuel cylinders listed above are approved for use in balloons covered by this Manual.

Unless otherwise stated the given weight values are valid for raw propane.

<b>NOTE</b>	<i>The Maxfill valve is set to approx. 80% of the water capacity, except for the fuel cylinders manufactured by KB - for these it is set to 85%.</i>
-------------	--

## 8.5 Table of Instruments

The following table lists instruments, which are approved for use in a Kubicek Balloon. If any other instrument has an approval for use in a hot air balloon given by a competent aviation authority, usage of such instrument(s) in a Kubicek Balloon is also allowed even if it is not listed in the following table.

Manufacturer	Instrument
Volirium AG, Naviter, Flytec	Flytec Element (Track, Speed, Alto), 3040
	6000, 6030, 6040, FB4
Flymaster	GPS LS
DigiTool Instruments AB	Dbi -002
	Dbi -003
Neue Aircotec GmbH	PICCOLO PLUS
Mikrotechna Praha a.s.	LUN 1124, LUN 1141, LUN 1147

INTENTIONALLY LEFT BLANK

## SECTION 9 - APPENDICES

### Appendix 1: Balloon Performance

The following table indicates balloon performance based of flight tests performed at the maximum takeoff weight and using average piloting techniques.

Model	Minimum Climb in first 60 s		Altitude Drop to Reach Max. Rate of Descent		Maximum Altitude Drop to Recover from the Max. Descent	
	[m]	[ft]	[m]	[ft]	[m]	[ft]
All BB models *	95 **	310 **	450	1 475	450	1 475
GP + M models	135	420	490	1 605	250	820
XR models	135	420	460	1 508	250	820

\* Applicable to all models of BB type models except below mentioned

\*\* The minimum attainable height for all BB type models

## Appendix 2: Basket Occupancy

In addition to the limitations in section 2 (Operational Limitations) and section 5 (Weight) the following factors should be considered when deciding how many occupants may be carried in a basket. This guidance assumes that the standard occupant is an adult with a mass of 77 Kg (170 lb).

The pilot should take into account the relative mass and size of the passengers and evenly distribute the payload when a compartmentalized basket is used.

The maximum number of occupants in each compartment or in an open basket is limited by the remaining floor area not occupied by fuel cylinders.

In all open baskets and in all separate compartments each passenger must have a minimum of 0.25 m<sup>2</sup> (2.6 sq ft) of floor area.

Floor areas occupied by fuel cylinders (CA) are:

0.15 m<sup>2</sup> (1.6 sq ft) - all cylinders, if not placed in a corner

0.11 m<sup>2</sup> (1.4 sq ft) - cylinders VA50, CB599, CV2385, CB2088, CB2387, V20, M-20, M-20D placed in a corner

0.13 m<sup>2</sup> (1.18 sq ft) - all other cylinders than the listed above, placed in a corner

Calculation of maximum occupancy of each compartment or open basket: 
$$N = \frac{FA - (NFC \times CA)}{0.25}$$

where  
N - maximum number of persons in compartment or open basket  
FA - actual basket floor area in m<sup>2</sup>, if not known take it from Chapter 2.10  
NFC - number of fuel cylinders  
CA - floor area occupied by cylinder

The result must be rounded down to the nearest whole number!

## Appendix 3: Kevlar Flying Cable Replacement

Kevlar flying wires are designed for simple replacement without any tools.

The kevlar flying cables consist of the Kevlar core covered with the heat resistant braid. A loop on one end attaches to a carabiner at the burner frame. The other loop end is attached to the envelope load tape loop.

Kevlar flying cables are to be inspected before every flight (see chap 4.3.8) and, if necessary, replaced as follows:

1. **Remove the existing cable by loosening the loop passing through the load tape loop at the envelope mouth. Prepare the new cable and check it is of the same length as the removed one.**
2. **Thread one flying cable loop through the load tape loop, then pass the other loop end through the loop.**
3. **Tighten the loop by pulling the cable while arranging the joint of the loops so the bends were as least sharp as possible.**

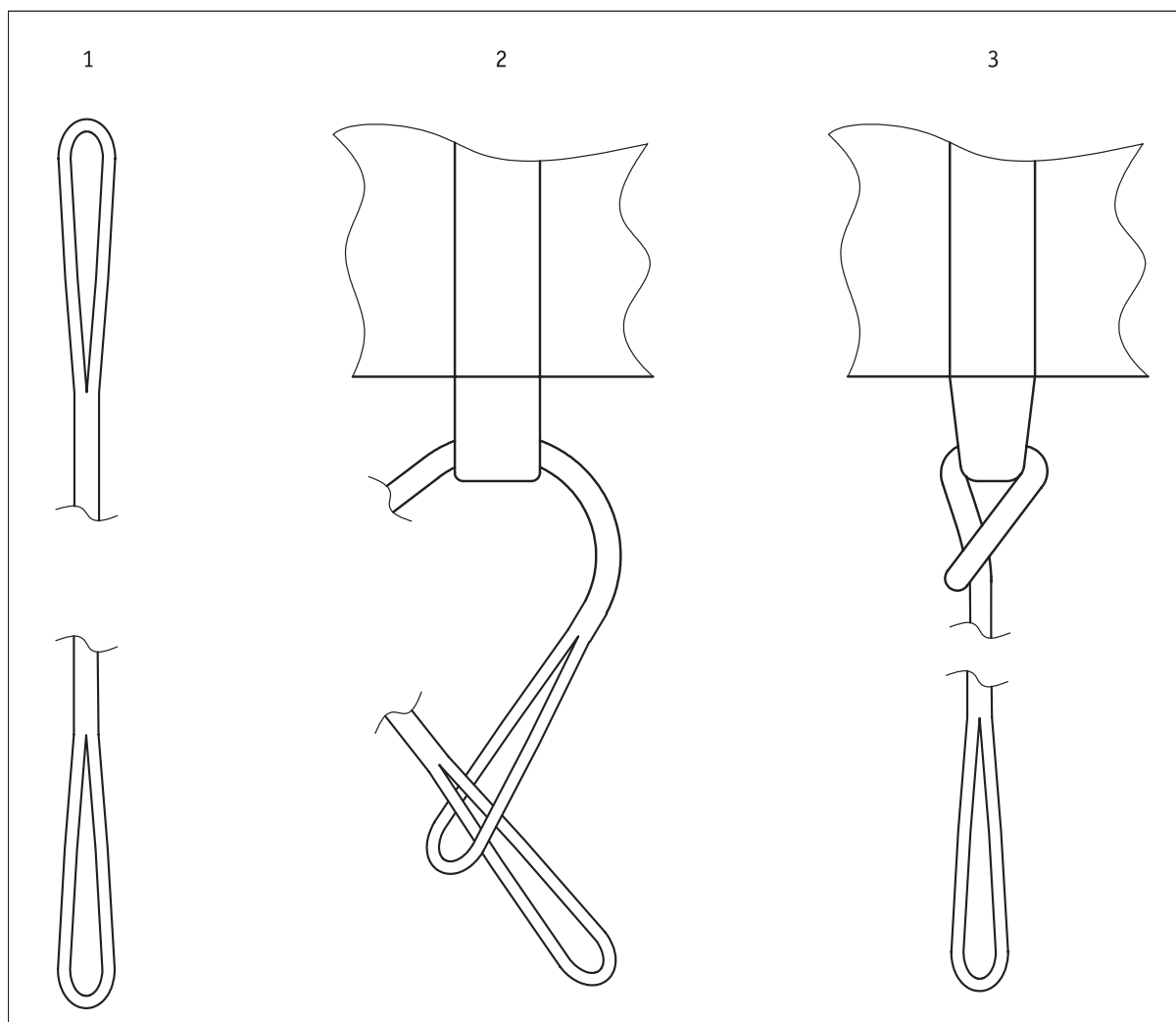

**WARNING** Do not use the kevlar line when the yellow core is visible! Do not use a kevlar line with lowered flexibility.

## Appendix 4: Baskets up to s/n 399

### Baskets Limitations:

Basket	Floor area		Load capacity		Max. Number of Occupants
	[m <sup>2</sup> ]	[sq. ft]	[kg]	[lb]	
K7	0.72	7.8	450	991	2
K10	0.89	9.6	600	1 322	3
K11	1.14	12.2	650	1 432	3
K12, K12A	1.35	14.5	700	1 542	4
K13	1.22	13.1	700	1 542	4
K13S	1,15	12,4	550	1 210	3
K15	1.45	15.6	800	1 762	5
K16	1.62	17.5	900	1 982	5
K17	1.68	18.4	900	1 982	5
K18	1.80	19.4	950	2 093	6
K22	2.24	24.1	980	2 159	8
K25P	2.60	28.0	1 000	2 203	8
K28	3.52	37.9	1 100	2 423	8
K32T	3.84	32.4	1 100	2 423	10
K32Y	3.84	32.4	1 100	2 423	10
K32TT	4.00	43.1	1 100	2 423	10
K40Y	4.08	43.9	1 200	2 643	12
K50	4.80	51.7	1 400	3 084	14
K50TT	4.80	51.7	1 400	3 084	14
K60	5.95	64.0	1 800	3 965	18
K70	6.48	70.0	3 000	6 601	22
K80	7.5	80.7	3 400	7 489	26
K100	9.76	105.0	4 000	8 811	30
K110	10.56	113.7	4 000	8 811	34

### WARNING

*K10 baskets up to s/n 123 are not allowed to be combined with Ignis - two units and Sirius burners (see FMS B.3102-OBFF for approved combinations).*

### Occupancy of Compartmentalised Baskets:

Basket	Max.Occupancy of Passenger Compartments	Max. Occupancy of Pilot Compartment	Pilot Compartment Floor Area	
			[m <sup>2</sup> ]	[sq. ft]
K28	3 persons	pilot + 1 person	1.32 (variant T) 1.12 (variant Y)	14.2 (variant T) 12.0 (variant Y)
K32T	4 persons	pilot + 1 person	1.19	12.8
K32Y	4 persons	pilot + 1 person	1.12	12.0
K32TT	2 persons	pilot + 1 person	1.32	14.2
K40Y	5 persons	pilot + 1 person	1.19	12.8



Basket	Max.Occupancy of Passenger Compartments	Max. Occupancy of Pilot Compartment	Pilot Compartment Floor Area	
			[m <sup>2</sup> ]	[sq. ft]
K50	6 persons	pilot + 1 person	1.32	14.2
K50TT	3 persons	pilot + 1 person		
K60	4 persons	pilot + 1 person	1.4	15.1
K70	5 persons	pilot + 1 person		
K80	6 persons	pilot + 1 person		
K100	outer comp.: 3 persons inner comp.: 4 persons	pilot + 1 person	1.84	19.8
K110	4 persons	pilot + 1 person	1.84	19.8

Table of Baskets

Basket Model	Basket Description	Typical Basket Weight*		Applicable Burners Frames	
		[kg]	[lb]		
K7	85 x 85 Open	50	110	Fixed or Vario Frame - basic	
K10	85 x 100 Open	60	132		
K11	98 x 116 Open	70	154		
K12, K12A	116 x 116 Open	80	176		
K13	116 x 125 Open	80	176		
K13S	95 x 126 Open	45	99		
K15	116 x 125 Open	85	187		
K16	116 x 140 Open	90	198		
K17	116 x 145 Open	90	198		
K18	116 x 155 Open	100	220		
K22	125 x 179 Open	105	241		
K25P	125 x 208, two partitions	135	297		Fixed Frame - K25P type
K28	160 x 220, T or Y three partitions	150	330		Fixed Frame - K32T type
K32T	125 x 241, T three partitions	160	352	Fixed Frame - K32T type	
K32Y	160 x 240, Y three partitions	170	352	Fixed Frame - K32T type	
K32TT	160 x 250, double T five partitions	170	352	Fixed Frame - K32TT or K50TT type	
K40Y	163 x 250, Y three partitions	220	485	Fixed Frame - K50 type	
K50	160 x 300, T or Y three partitions	270	594	Fixed Frame - K50 type	
K50TT	160 x 300, double T five partitions	300	661	Fixed Frame - K32TT or K50TT type	
K60	170 x 350, double T five partitions	320	705	Fixed Frame - K60 type or K60 STRONG type	
K70	170 x 400, double T five partitions	400	881		
K80	170 x 450, double T five partitions	450	991		
K100	160 x 610, nine partitions, double double T	550	1 211	Fixed Frame - K100 type	
K110	160 x 660, nine partitions, double double T	600	1 322	Fixed Frame - K100 type	

\* Typical basket weight includes: Fire extinguisher, Fire blanket, Drop line of a length at least 25m (82 ft) and First aid kit.

<b>NOTE</b>	<i>The actual basket weight is indicated on the basket identification plate.</i>
-------------	--

## Appendix 5: Minimum Fuel Hose Radius

Minimum fuel hose radius template (take the scale into consideration):

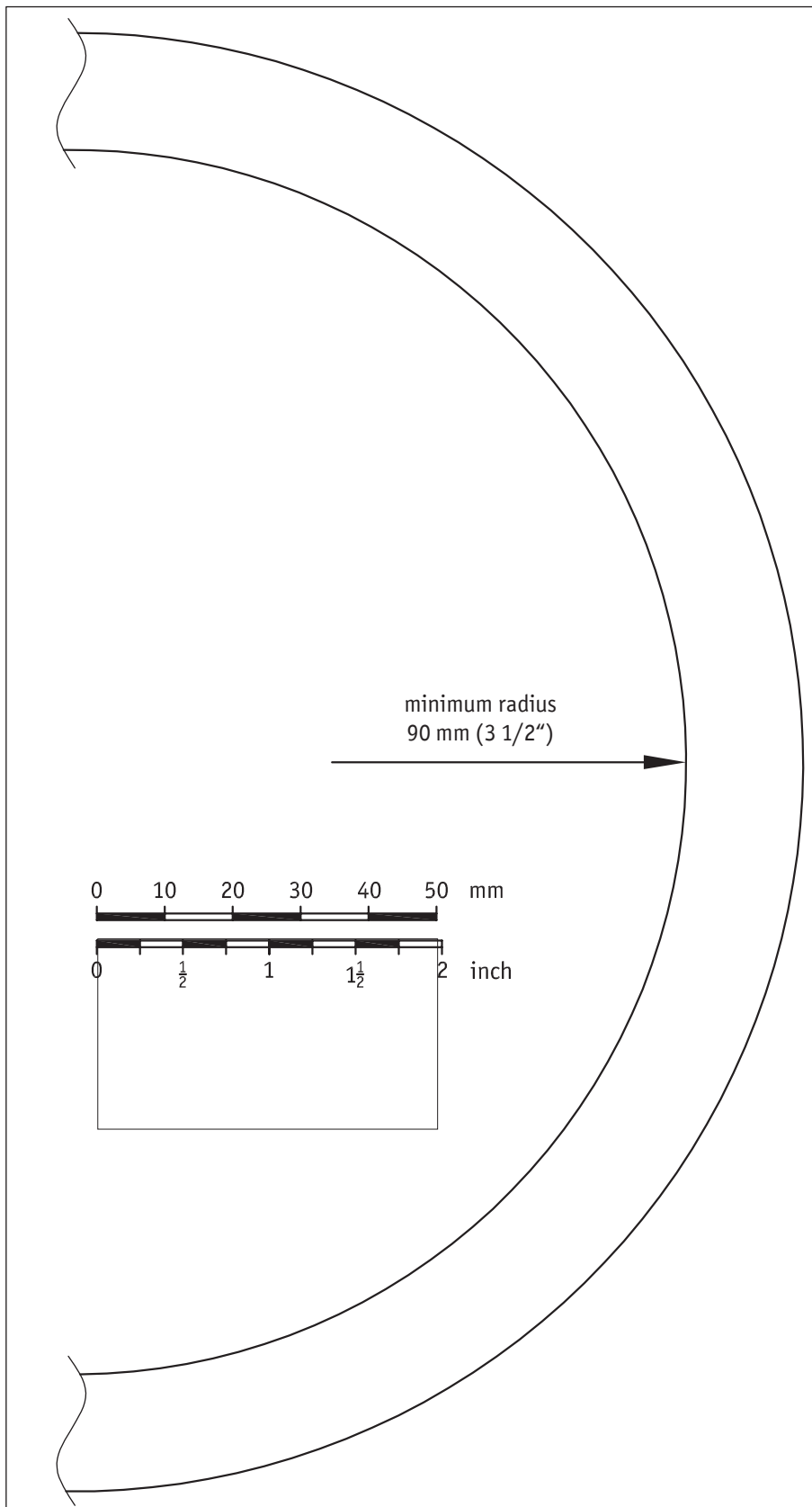

**Appendix 6: Limits for baskets K32T or K40Y**

Additional limits apply when baskets K32T or K40Y fitted with burner frames without the symbol S/N before their serial number are used:

The maximum surface wind speed for take-off for BB60N and BB60Z is **6.0 m/s (11.7 kts)**.

The maximum surface wind speed for take-off for BB70Z is **5.5 m/s (10.7 kts)**.

See also Chapter 2.25.

## Appendix 7: Location of temperature measuring equipment

In case of certain customer modifications of the envelope, location of the temperature measuring equipment (Tempilabel, Temperature Streamer and Electronic Thermometer attachment point) may differ to the one stated in the chart below. When in doubt about the correct location, contact the manufacturer.

Envelope	Number of gores	Tempilabel		Temperature Streamer		Electronic Thermometer attachment point	
		Gore number	Number of panels from vent hole	Gore number	Number of panels from vent hole	Load tape number	Distance from envelope top edge
BB9E	8	7	2	7	2	6	1 m (3.3 ft)
BB12E	8	7	2	6	2	6	1 m (3.3 ft)
BB16E	8	7	2	6	2	6	1 m (3.3 ft)
BB18E	12	10	2	9	2	9	1 m (3.3 ft)
BB20E	12	10	2	9	2	9	1 m (3.3 ft)
BB22E	12	10	2	9	2	9	1 m (3.3 ft)
BB26E	12	10	2	9	2	9	1 m (3.3 ft)
BB30E	12	10	2	9	2	9	1 m (3.3 ft)
BB34E	12	10	2	9	2	9	1 m (3.3 ft)
BB9EF	12	10	2	10	2	9	1 m (3.3 ft)
BB12EF	12	10	2	10	2	9	1 m (3.3 ft)
BB16EF	12	10	2	10	2	9	1 m (3.3 ft)
BB20ED	12	9	2	9	2	9	1 m (3.3 ft)
BB22ED	12	9	2	9	2	9	1 m (3.3 ft)
BB26ED	12	9	2	9	2	9	1 m (3.3 ft)
BB30ED	12	9	2	9	2	9	1 m (3.3 ft)
BB34ED	12	9	2	9	2	9	1 m (3.3 ft)
BB22Z	24	21	4	18	4	20	1 m (3.3 ft)
BB26Z	24	21	3	18	3	20	1 m (3.3 ft)
BB30Z	24	21	3	18	3	20	1 m (3.3 ft)
BB34Z	24	21	4	18	4	20	1 m (3.3 ft)
BB37Z	24	21	3	18	3	20	1 m (3.3 ft)
BB40Z	24	21	3	19	3	20	1 m (3.3 ft)
BB42Z	24	21	3	18	3	20	1 m (3.3 ft)
BB45Z	24	21	4	18	4	20	1 m (3.3 ft)
BB51Z	24	21	4	18	4	20	1 m (3.3 ft)
BB60Z	24	21	3	18	3	20	1 m (3.3 ft)
BB64Z	24	21	3	19	3	20	1 m (3.3 ft)
BB70Z	24	21	3	19	3	20	1 m (3.3 ft)
BB78Z	24	21	3	19	3	20	1 m (3.3 ft)
BB85Z	28	24	4	21	4	23	1 m (3.3 ft)
BB92Z	28	24	2	21	2	23	1 m (3.3 ft)
BB100Z	28	24	3	21	3	23	1 m (3.3 ft)
BB22D	24	21	3	18	3	20	1 m (3.3 ft)

Envelope	Number of gores	Tempilabel		Temperature Streamer		Electronic Thermometer attachment point	
		Gore number	Number of panels from vent hole	Gore number	Number of panels from vent hole	Load tape number	Distance from envelope top edge
BB26D	24	21	3	18	3	20	1 m (3.3 ft)
BB30D	24	21	3	18	3	20	1 m (3.3 ft)
BB34D	24	21	4	18	4	20	1 m (3.3 ft)
BB37D	24	21	3	18	3	20	1 m (3.3 ft)
BB40D	24	21	3	19	3	20	1 m (3.3 ft)
BB42D	24	21	3	18	3	20	1 m (3.3 ft)
BB45D	24	21	4	18	4	20	1 m (3.3 ft)
BB51D	24	21	4	18	4	20	1 m (3.3 ft)
BB60D	24	21	3	18	3	20	1 m (3.3 ft)
BB70D	24	21	3	19	3	20	1 m (3.3 ft)
BB85D	28	24	3	21	3	23	1 m (3.3 ft)
BB100D	28	24	3	21	3	23	1 m (3.3 ft)
BB105P	28	24	4	21	4	23	1 m (3.3 ft)
BB106P	28	24	4	21	4	23	1 m (3.3 ft)
BB113P	28	24	3	19	3	23	1 m (3.3 ft)
BB120P	28	24	4	21	4	23	1 m (3.3 ft)
BB130P	28	24	4	21	4	23	1 m (3.3 ft)
BB142P	32	25	4	23	4	25	1 m (3.3 ft)
BB150P	32	25	4	23	4	25	1 m (3.3 ft)
BB184P	32	25	3	23	3	25	1 m (3.3 ft)
BB14XR	16	13	2	12	2	12	1 m (3.3 ft)
BB16XR	16	13	2	12	2	12	1 m (3.3 ft)
BB17XR	16	13	2	12	2	12	1 m (3.3 ft)
BB18XR	16	13	2	12	2	12	1 m (3.3 ft)
BB20XR	16	13	2	12	2	12	1 m (3.3 ft)
BB20XR (UP TO AND INCLUDING S/N 2160)	20	14	2	14	2	14	1 m (3.3 ft)
BB22XR	24	20	2	20	2	20	1 m (3.3 ft)
BB26XR	24	20	2	20	2	20	1 m (3.3 ft)
BB30XR	24	20	3	20	3	20	1 m (3.3 ft)
BB22M	12	11	2	10	2	10	1 m (3.3 ft)
BB26M	12	11	3	10	3	10	1 m (3.3 ft)
BB30M	12	11	2	10	2	10	1 m (3.3 ft)
BB9	8	7	2	7	2	6	1 m (3.3 ft)
BB12	8	6	2	7	2	6	1 m (3.3 ft)
BB16	8	7	2	6	2	6	1 m (3.3 ft)
BB20	12	9	3	7	3	9	1 m (3.3 ft)
BB22	12	10	2	9	2	9	1 m (3.3 ft)
BB26	12	10	2	9	2	9	1 m (3.3 ft)

# KUBICEK

<i>Envelope</i>	<i>Number of gores</i>	<i>Tempilabel</i>		<i>Temperature Streamer</i>		<i>Electronic Thermometer attachment point</i>	
		<i>Gore number</i>	<i>Number of panels from vent hole</i>	<i>Gore number</i>	<i>Number of panels from vent hole</i>	<i>Load tape number</i>	<i>Distance from envelope top edge</i>
<i>BB22N</i>	<i>24</i>	<i>20</i>	<i>1</i>	<i>17-18</i>	<i>1</i>	<i>20</i>	<i>1 m (3.3 ft)</i>
<i>BB26N</i>	<i>24</i>	<i>20</i>	<i>1</i>	<i>17-18</i>	<i>1</i>	<i>20</i>	<i>1 m (3.3 ft)</i>
<i>BB30N</i>	<i>24</i>	<i>20</i>	<i>1</i>	<i>17-18</i>	<i>1</i>	<i>20</i>	<i>1 m (3.3 ft)</i>
<i>BB37N</i>	<i>24</i>	<i>20</i>	<i>1</i>	<i>17-18</i>	<i>1</i>	<i>20</i>	<i>1 m (3.3 ft)</i>
<i>BB45N</i>	<i>24</i>	<i>20</i>	<i>1</i>	<i>17-18</i>	<i>1</i>	<i>20</i>	<i>1 m (3.3 ft)</i>
<i>BB60N</i>	<i>32</i>	<i>25</i>	<i>1</i>	<i>22-23</i>	<i>1</i>	<i>25</i>	<i>1 m (3.3 ft)</i>
<i>BB17GP</i>	<i>16</i>	<i>14</i>	<i>3</i>	<i>12</i>	<i>3</i>	<i>13</i>	<i>1 m (3.3 ft)</i>
<i>BB20GP</i>	<i>24</i>	<i>21</i>	<i>2</i>	<i>18</i>	<i>2</i>	<i>20</i>	<i>1 m (3.3 ft)</i>

## Appendix 8: Additional Information for Collapsible Baskets K10C and K13C

### 1. Description Of The Collapsible Basket

The collapsible baskets are made of double-walled fabric sidewalls instead of traditional wickerwork sides. The landing side of K10C and K13C basket is the same as downwind side and it is reinforced with protection plates. Frame structure is made of stainless steel. The vertical impact-absorbing elements of the basket are 8 flexible parts of the rods combined with stainless steel parts. The rods on the short sides are collapsible. Hinge joints are locked by the steps which are secured by the red velcros. The rods with holes for locking pins are on the long sides. The door (hatch) is used to load and unload fuel cylinders and for passengers. Passengers can also use the steps on the short sides. The equipment pocket is fixed to the vertical straps on the landing side of the basket. The zipper sliders are secured in their flight position by carabiners. Soft foam is placed on the floor.

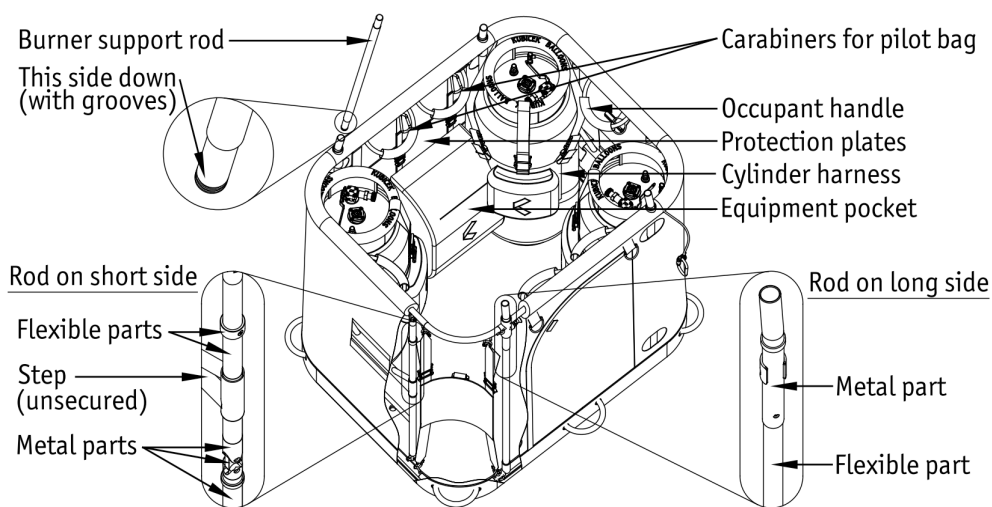
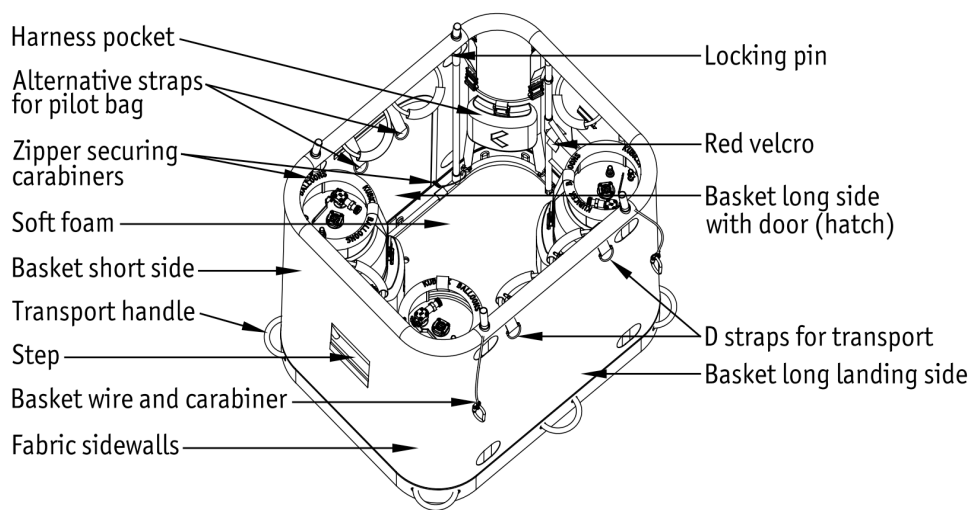

## 2. Assembling of the Basket (additional information to 4.3.5.)

- Pull steps up gradually to straighten rods on the short side of the basket. Once latched secure the steps with red velcro - pic. 1.

Pic. 1

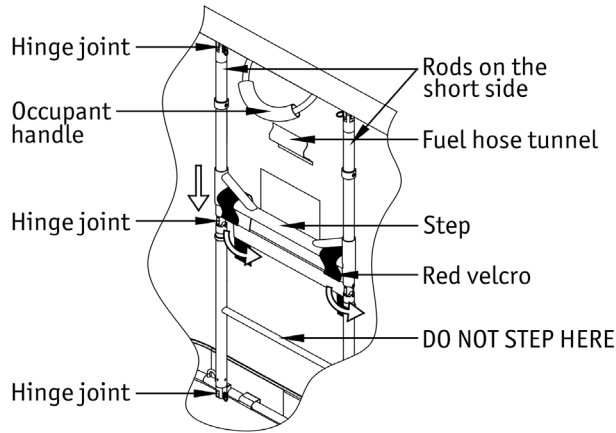

- Insert the 4 rods through top frame sockets into the bottom frame sockets and turn them into lock position. Make sure the basket wires are not wrapped around the rods.
- Turn the 4 locking pins of the rods to the locked and stable position - pic. 2.

Pic. 2

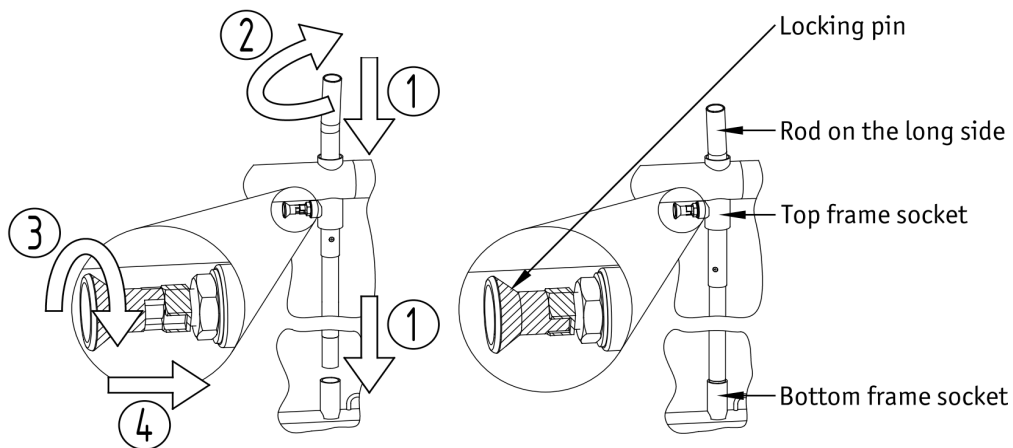

- When loading fuel cylinders into the basket, use the two corners on the landing (downwind) side first.
- If Master fuel cylinders are used place them preferably to the downwind side of the basket.

<b>CAUTION</b>	When more than two Master fuel cylinders are loaded in the basket it is allowed to connect the vapour fuel offtake only of the two cylinders located on the downwind side.
----------------	--



- Each of the 4 cylinder harnesses must be tightened.
- Tighten all three straps to secure the cylinder in the harness.
- In case there is no fuel cylinder located tighten two side straps of the harness. Hide the unused middle strap into the harness pocket.

Cylinder harness with fuel cylinder

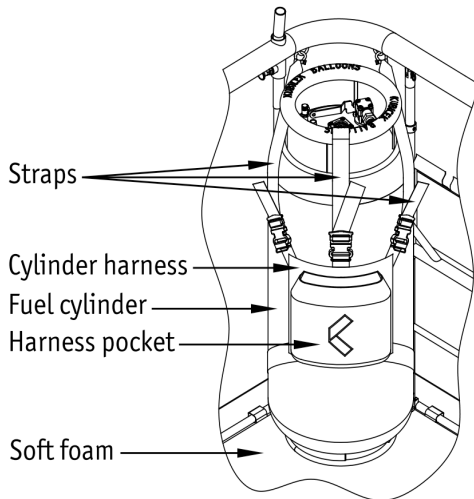

Cylinder harness without fuel cylinder

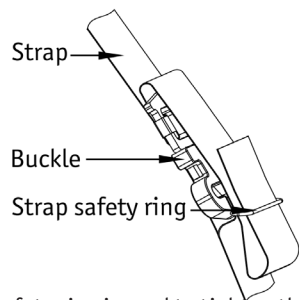
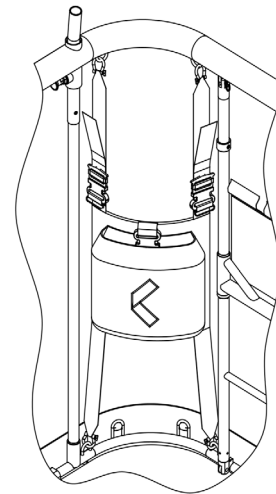

The strap safety ring is used to tighten the loose end of the strap.

PRESS TO RELEASE

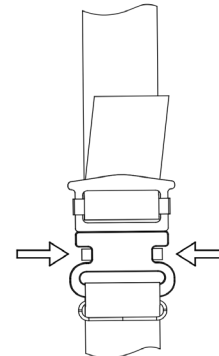

- Lead fuel hoses on the short side of the basket through the tunnels on the sidewalls - pic. 3.

Pic. 3

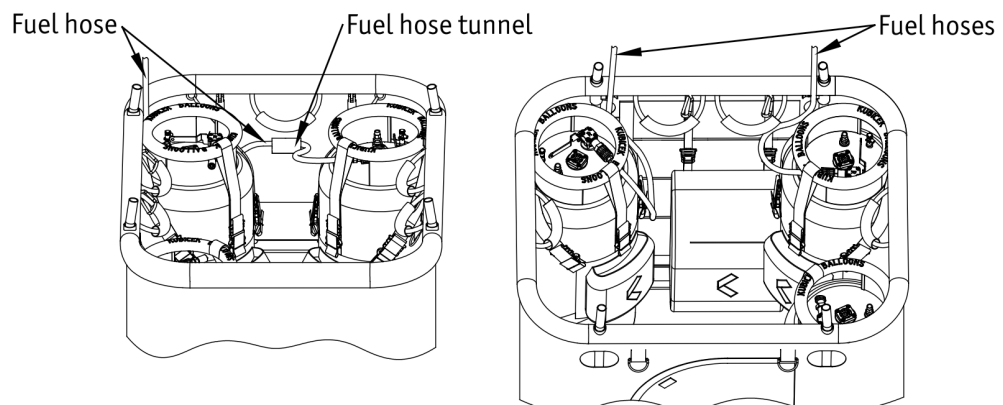

- Inspect the conditions of the burner support rods and put them into the sockets in the top frame of the basket. Inspect the general conditions of the burner and burner frame and place the burner on top of the rods with the red-marked hose on the right side.
- Ensure that the basket wires are not wrapped around the rods on the long sides of the basket and the burner support rods. Check that the wire is attached to the burner frame on the same side as the wire exits around the socket on the upper frame of the basket.
- Attach the pocket to the buckles and to the carabiner strap rings. Tighten the pocket straps - pic. 4.

**Pic. 4**

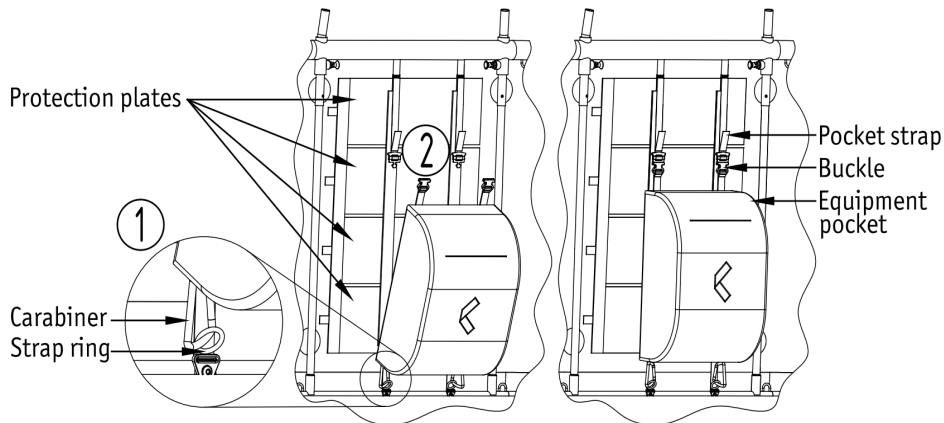

- Inspect the condition of fabric sidewalls, zippers and their sliders, rods and their locking pins and hinge joints. Secure the upper zipper with a red carabiner.

## 2. Packing of the Collapsible Baskets K10C and K13C (additional information to chapter 4.5.6.)

- Release the straps of the pocket and remove the pocket from the basket.
- Release the 4 cylinder harnesses and remove fuel cylinders from the basket.
- Pull out 4 locking pins of the rods and turn them to unlocked position.
- Turn the 4 rods and remove them from the basket by pulling upwards.

### Unlocked position of the rod.

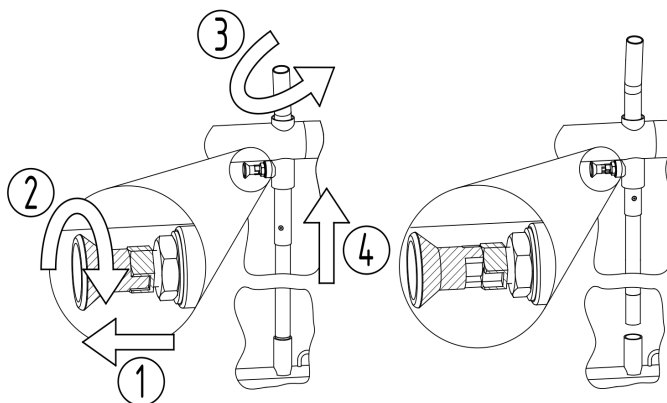

- Tear off the velcro securing the steps and pull steps up gradually to collapse the basket.
- Adjust the fabric sidewalls and protection plates on the basket.
- Put the top frame sockets inside the bottom frame sockets.
- Place the basket into the bag, if available.

**3. Cleaning and care** (additional information to chapter 7.5.2.)

The fabric sidewalls are removable for cleaning and repair purposes. They can be cleaned with warm water at a temperature of max 40 degrees Celsius with mild washing powders or detergents. Best way to remove the fabric sidewalls is when the steps are locked, red velcros are not secured and the rods on the long sides are not inserted. Pull up the straps (the ones used for the equipment pocket), remove the protection plates, open the door zipper as well as the bottom and upper zippers and pull the sidewalls up over the upper frame of the basket.

## **LET US HELP YOU!**

In case that you have any suggestion, difficulty, problem or comment, please contact our technical department at:

technical@kubicekfactory.com  
+420 545 422 638

**Kubíček Factory s.r.o.**  
info@kubicekfactory.com • www.kubicekfactory.com  
Brno 614 00 • Jarní 1003/2a • Czech Republic  
+420 545 422 620

© Copyright Kubíček Factory s.r.o.